



Instruction Manual

Scrubmaster B310 R (7580.34)

Introduction

Preface

Dear Customer,

We are certain that the excellent qualities of the vehicle will justify the faith you have shown in us through your purchase.

Your safety, and that of others, basically lies in your ability to control and operate the vehicle. Before using the vehicle for the first time, read this original manual thoroughly, act according to the information contained and keep it in a safe place for future reference or subsequent owners. Please read the Chapter "Safety Information" prior to starting the vehicle to ensure it is operated and used safely.

The operating manual contains all the most important information regarding operation, maintenance and service. Throughout this manual, texts which concern safety are indicated by the corresponding danger pictogram. Should you have any questions in respect of the vehicle or operating instruction manual, your authorized Hako dealer is available to provide help at any time.

We explicitly point out that no legal claims may be asserted based on the information contained in this manual. Please pay attention that only original spare parts are used for any necessary maintenance and repair work. Only original spare parts can guarantee long, reliable equipment operation. We reserve the right to make technical improvements.

Valid from: April 2014

Hako GmbH
23843 Bad Oldesloe
Hamburger Straße 209-239
Telephone: +49 4531 806-0

Intended use

The Scrubmaster B310 R is a large-area scrubber-drier designed for wet cleaning rough and structured hard floors inside buildings, such as in multi-storey car parks or logistics and industrial areas. This machine is intended for commercial use. Any use beyond this is regarded as improper use. The manufacturer is not considered liable for any damage resulting from improper use; the user is solely responsible for all the risks.



The scrubber drier has not been approved for use on public paths and roads.

Intended use also includes maintaining and observing the operating, maintenance and repair conditions prescribed by the manufacturer.

The scrubber drier may only be operated, serviced and repaired by personnel who are familiar with the work involved and are aware of the risks.

The applicable accident prevention laws must be observed and any generally accepted health and safety directives must be maintained.

Introduction

Based on the conception, design and construction of the vehicle introduced onto the market by us, the vehicle complies with the applicable basic safety and health requirements stipulated in the EC Directive (refer to the Declaration of Conformity). This declaration is no longer considered valid in the event of modifications to the vehicle not authorized by us. The manufacturer is not deemed liable for any damage resulting from unauthorized modifications to the vehicle.

Notes on warranty

The terms defined in the purchase agreement related to damage are excluded from the terms of warranty when the damage is the result of failure to observe regulations concerning service and maintenance. Maintenance work must be performed by authorized Hako service centers and confirmed in the "Maintenance Report" which serves as a warranty logbook.

The following are excluded from the terms of warranty: wear and tear through overuse, defective fuses, improper handling and use or unauthorized modifications. Claims under the terms of warranty are annulled when damage occurs to the vehicle resulting from the use of parts or accessories not explicitly approved by us or from failure to observe maintenance regulations.

Acceptance of the machine

Inspect the vehicle immediately on delivery for signs of transport damage. These will be replaced when the damage is immediately confirmed by the haulage contractor and the damage report is sent to our authorized sales partner together with the consignment note.

Contents



Introduction	2	2.3	Prior to starting up for the first time	19	3.2	Operating and indicator elements.	38
Preface	2						
Intended use	2	2.3.1	Assembling and disassembling brushes and pads.	19	3.2.1	Operating elements in the driver's cab.	38
Notes on warranty	3						
Acceptance of the machine	3	2.3.2	Installing and adjusting the squeegee	24	3.2.2	Left-hand operating panel	41
		2.3.3	Adjusting the driver's seat	25	3.2.3	Right-hand operating panel	47
1 Safety Information	6	2.4	Before starting up daily	26	3.2.4	Operating elements on the machine	50
1.1	Safety and warning symbols				3.3	Operation	54
1.2	General information	3	Operation	27	3.3.1	Switching the machine on	54
1.3	Operating information.	3.1	Method of operation	27	3.3.2	Accelerating	55
1.4	Maintenance information	3.1.1	Scrubbing unit	27	3.3.3	Stopping and parking.	55
1.5	Particular risks	3.1.2	Squeegee.	29	3.3.4	Cleaning.	55
1.5.1	Electronics	3.1.3	Suction turbines (suction).	29	3.3.5	Switching the machine off	58
1.5.2	Batteries	3.1.4	Solution tank	29	3.3.6	Loading and transporting the vehicle	58
1.6	Environmental protection	3.1.5	Waster water tank	31			
1.7	Labels on the vehicle	3.1.6	Traction drive	31	3.4	After finishing work.	59
		3.1.7	Brakes	31	3.5	Function faults	60
2 Starting Up	18	3.1.8	Batteries and charger.	32	3.5.1	Error code table	60
2.1	Instruction.	3.1.9	Options.	34	3.5.2	Other function faults.	61
2.2	Initial battery charge.						

Safety Information

1 Safety Information

1.1 Safety and warning symbols

All texts related to personal safety, safety of the vehicle and environmental protection are assigned the following symbols throughout the operating manual:

Symbol	Risks to ...	Definition
Safety information 	persons or property	Safety information to prevent the development of hazardous situations resulting from ignoring or failing to follow instructions or prescribed work procedures.
Note 	the machine	Important information on handling the equipment in order to maintain its functionality.
Ecological hazard 	the environment	Ecological hazard through the use of substances which represent a potential hazard to health and the environment.

Safety Information

1.2 General information

- The scrubber drier fulfills all the applicable safety and health requirements stipulated in the EC directives with regard to its planning, constructional design and final construction as introduced by us onto the market. In the case of modifications to the vehicle not approved by us, the EC Declaration of Conformity enclosed in this operating manual loses its validity.
- In addition to the information provided in this operating manual, all the legally applicable health and safety provisions must be observed.
- Before starting up the vehicle for the first time, read the operating manual supplied with it thoroughly as well as any separate manuals provided with additional or attachment devices and observe all the information during work.
- The vehicle may only be operated, maintained and repaired by persons trained by Hako or authorized to do so by Hako.
- This vehicle is not intended to be used by persons (including children) with limited physical or mental capabilities or persons without sufficient experience and ability.
- Particular attention should be paid to the information regarding safety. Technical expertise is the key to preventing errors when operating the equipment and ensuring trouble-free operation.
- The operating manual must always be kept at the operating location of the vehicle and, as a result, should be kept in a safe place on the vehicle.
- If the equipment is sold or rented out, these documents should be transferred to the new owner/operator. The transfer should be confirmed!
- The warning labels attached to the equipment provide important information concerning safe operation. Labels which are illegible or missing must be replaced.
- Original spare parts must be used to ensure safety.
- If you want to shut the vehicle down, render it inoperable. It must not represent a source of danger for children.

Safety Information

1.3 Operating information

- Before starting the vehicle up for the first time, the battery to be used must be fully charged, properly, by implementing the initial battery charge routine. Please pay attention to the operating manual provided with the charging unit as well as the manual from the battery manufacturer. Hako assumes no liability for damage to the battery caused by a fault when the battery is charged for the first time.
- Before starting the vehicle up, always check it is in a proper condition and that it is safe to drive and operate. Clear up any faults and defects immediately! Never operate the vehicle without functional safety equipment.
- Warning: Do not use the vehicle without a protective roof structure (refer to "Accessories", "Cab safety roof") in areas where the driver is at risk of being hit by falling objects (e.g. warehouses). Contact the trade association responsible for you as to whether obligations exist in this respect.
- The scrubber drier must be

subjected to an inspection in respect of its operationally safe condition at least once a year by an authorized technical expert. The results of the inspection must be documented in writing and kept safe at least until the next inspection.

- Floor cleaning machines may only be operated by suitable personnel who have been trained to operate the equipment, have proven their capability to operate the vehicle to the contractor or person appointed by him and have been explicitly charged by him to operate the vehicle.
- Before starting work, operating personnel must be fully familiar with all adjustment, operating and control elements as well as their respective function! It is too late to do this when the vehicle is actually in operation!
- The warning labels attached to the scrubber drier provide important information concerning safe operation.
- Wet floors are a potential risk for slipping! Ensure to provide the corresponding information and warning signs.

- If the floor is excessively wet, check the vehicle for leaks and that the sealing strips are in a good condition. If the sealing strips are damaged, change them immediately.
- Only use cleaning agents suitable for the vendor (non-foaming) and observe all the use, disposal and warning information provided by the cleaning agent manufacturer.
- It is forbidden to use the vehicle in potentially explosive atmospheres.
- The vehicle is not suitable for clearing up health-hazardous, inflammable or explosive fluids or dusts and substances with similar properties.
- Ride-on equipment may only be set into motion from the seat (seat contact switch).
- The seat contact switch must never be bypassed or the function immobilized in any way (e.g. by placing a heavy load on the seat).
- It is forbidden to transport people on the vehicle!
- Always wear heavy duty, non-slip footwear when working with the vehicle.

Safety Information

- Start driving immediately after switching on the brush head drive otherwise imprints of the brush could be produced on the floor.
- The machine may only be driven on and the equipment used on those surfaces which have been approved by the contractor or person appointed by him.
- The manner of driving must be adapted to the local conditions (floor characteristics, presence of persons in the vicinity, obstacles, etc.).
- When using the vehicle, it is essential to pay attention to third parties, especially children.
- Never leave the vehicle unattended while motors are still running and it has not been locked against unintended movement.
- To prevent authorized use of the vehicle, lock the drive by removing the key from the key switch.
- When transporting the vehicle, the motors must be shutdown.
- Only open empty recovery tanks.
- The scrubber drier may only be driven on hard-surfaced, sufficiently non-slip ground (e.g. asphalt, concrete) which is free of oil, water, snow etc.
- The vehicle may only be driven on gradients to a maximum of 6% for a maximum of five minutes when in work mode. Do not drive the vehicle on slopes with a gradient steeper than the limit gradient indicated on the vehicle.
- The vehicle may only be driven on gradients to a maximum of 15% for a maximum of one minute when in transport mode. When driving the vehicle in transport mode, the ground must be clean and dry, i.e. free of dirt, oil, snow, water etc., particularly when driving on gradients.

Safety Information

1.4 Maintenance information

Properly completed vehicle maintenance is an important protective measure in preventing accidents.

- The maintenance work and maintenance intervals prescribed in the operating manual must be adhered to.
- Operating personnel must complete the necessary daily and weekly maintenance work. All other maintenance work must be completed at your nearest authorized Hako service center.
- Before starting any cleaning and maintenance work or replacing parts, switch off the motors, remove the key from the key switch and pull out the battery plug. This is particularly important in respect of work on the electrical system!
- Before working on the brushes, switch off the scrubbing unit, set the key switch to position 0 and remove the key.
- The scrubbing unit may only be disassembled and installed by service personnel.
- Suitable tools must be used for cleaning and maintenance work.
- Spare parts must comply with the minimum technical requirements stipulated by the manufacturer! This is ensured by the use of original spare parts.
- When working in the area of the raised seat console, it must be pivoted up fully to prevent it accidentally closing or suddenly slamming shut.
- It is not permitted to clean the vehicle with a pressure washer or steam blaster.
- Clean the recovery tank regularly to protect it from the accumulation of dirt, viruses, bacteria, etc.
- It is not permitted to use aggressive and corrosive cleaning agents.
- Allow the machine to dry after being cleaned, e.g. over the weekend.
- The vehicle must be checked by a recognized technical expert in respect of operational safety at reasonable intervals (we recommend at least one a year), particularly with regard to protective equipment and locks and following modifications or repair.
- Only start the machine up when all the safety equipment has been installed, is functional and brought to its protecting position.
- The vehicle has been set up for operation using low-maintenance trough batteries. If other battery types are to be used, the vehicle must be adjusted for them by an authorized Hako service center.
- Observe the information in the operating manual provided by the battery manufacturer. These must be available to operating and maintenance personnel at all times.
- Batteries may only be handled and changed by properly skilled maintenance personnel.
- When installing the trough battery, use appropriate lifting gear.
- Only use batteries and chargers recommended by us. The full terms of warranty can only be accepted when these units are used.
- Pay attention that the insulation on the charger is not initially damaged and not damaged during the charging process. The cable must not rub against anything. Do not use the charger if the insulation is damaged.
- Always wear appropriate protective

Safety Information

clothing when handling the battery (e.g. protective gloves, finger stalls, protective goggles).

- The seat console must be pivoted open during the battery charging process to prevent the development of explosive oxyhydrogen!
- Never leave the batteries in a discharged state but recharge them as soon as possible.
- Only refill distilled water.
- When the cells are in good condition, never refill the battery acid.
- Spilled battery acid must never enter the sewage system in its initial form, it must be neutralized beforehand.
- Pay attention to legal requirements and local directives.
- For further safety information, see supplementary sheet 88-60-2556 "Notes on driving batteries".

1.5 Particular risks

- The following applies when locating and clearing faults: Switch the vehicle off, remove the key from the key switch and disconnect the battery plug!
- In the case of faults involving the

traction drive, stop the vehicle immediately and remove the key from the key switch!

1.5.1 Electronics

- Always disconnect the battery plug before starting any work on the electrical installations.
- Only use original fuses with the prescribed amperage.
- In the case of defects in the electrical installation, switch the vehicle off immediately and clear the fault.
- Work on the electrical equipment may only be carried out by electricians who have received the necessary training and in accordance with the electrical engineering regulations.
- The vehicle's electrical equipment must be inspected/checked at regular intervals. Defects, such as loose connections and cable damage, must be rectified immediately.

Safety Information

1.5.2 Batteries

- Due to a change in the center of gravity, only approved batteries may be installed at the intended position.
 - To prevent creeping currents, always keep the batteries clean and dry and protect from contamination, e.g. from metal dust.
 - Never lay any metallic objects or tools on batteries. Risk of short circuit and deflagration!
 - Ensure sufficient ventilation in the charging area when charging the batteries. Otherwise there is a risk of explosion!
 - The seat console must be pivoted open during the battery charging process to prevent the development of explosive oxyhydrogen!
 - Only use recommended chargers! Pay attention that the insulation is not initially damaged and not damaged during the charging process. The cable must not rub against anything. Do not use the charger if the insulation is damaged.
 - Ensure there are no naked flames nearby when handling batteries, particularly when checking the acidity. Risk of explosion!
- Do not inhale battery gases.
 - Battery acid is very corrosive; keep away from children.
 - Wear protective goggles when controlling the acid level.
 - In the event of acid splashing in the eyes, rinse them with water for approx. 15 minutes and seek medical attention immediately.
 - Also pay attention to the information in Section 1.4.

1.6 Environmental protection

- A certain factual expertise is required in order to use substances which could represent a risk to health and the environment.
- Always observe legal regulations and local directives when disposing of cleaning agents, also refer to the Water Resources Act (German: WHG).

Safety Information

Disposing of batteries

- Used batteries with the recycling symbol contain reusable commodities. The heavy metals contained represent a major risk both to people's health and to the environment. Never open or damage batteries. Never touch, inhale or swallow the content of batteries. Health hazard! Do not allow batteries to get into the environment. Risk of contaminating the ground and water! In accordance with symbol with the crossed out garbage bin, these batteries must not be disposed of in domestic waste. Return and recycling of old batteries must be agreed on with Hako's authorized dealers in accordance with § 6 and § 8 German Battery Law (BattG).

Disposing of the vehicle

- Render the vehicle inoperable. It must not represent a source of danger for children.
- Dispose of the vehicle in accordance with local regulations. For further information on handling and recycling, please contact the authorized Hako dealer where you purchased the vehicle.

Safety Information

1.7 Labels on the vehicle

The following safety and warning labels are attached to the vehicle where easily legible.



Missing or illegible labels must be replaced immediately.

Company logo (Fig. 1/1) (Fig. 2/1)

Hako

Read the operating manual, maximum gradient and ban on cleaning using a high-pressure washer (Fig. 1/2)

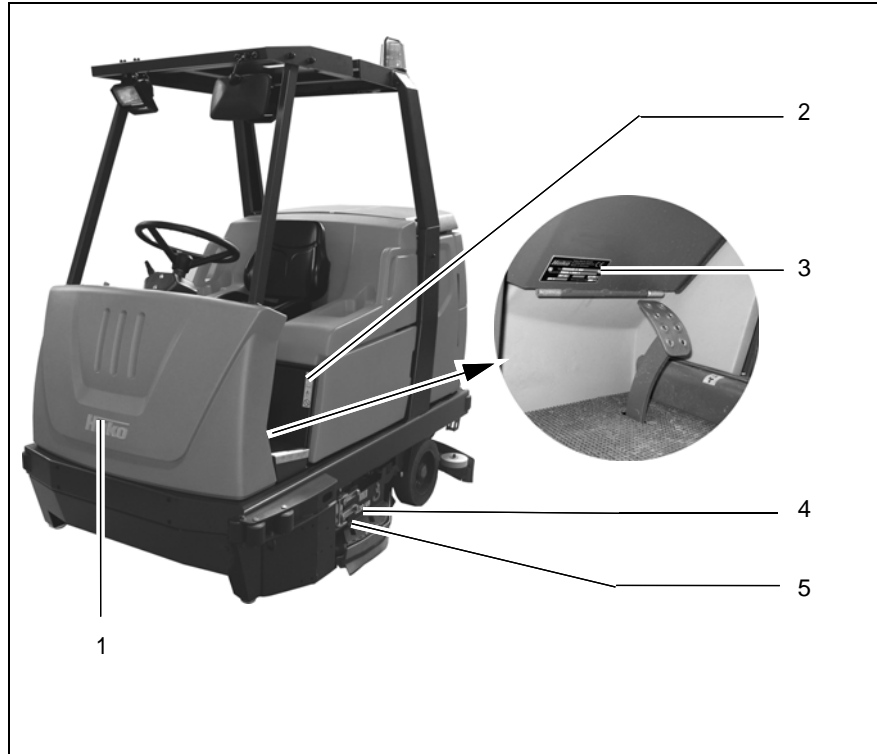
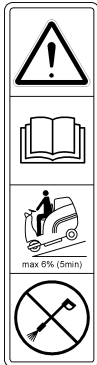

Fig. 1

Safety Information

Rating plate (Fig. 1/3)

The rating plate is in the driver's cab, at the bottom on the flap of the left-hand electrical compartment.



Working width in millimeters (mm) and inches (in) (Fig. 1/5)

The working width of the machine is specified in millimeters and in inches on the deflectors to the left and right: The Scrubmaster B310 R has a working width of 1230 mm or 49 in.

1230/49

No standing on the deflectors (Fig. 1/4)



Safety Information

Drive direction selector:

Forwards or reverse (Fig. 2/6)



Release parking brake

(Fig. 2/7)



Apply parking brake

(Fig. 2/8)



Maximum water temperature for

water to be filled

(Fig. 2/9)

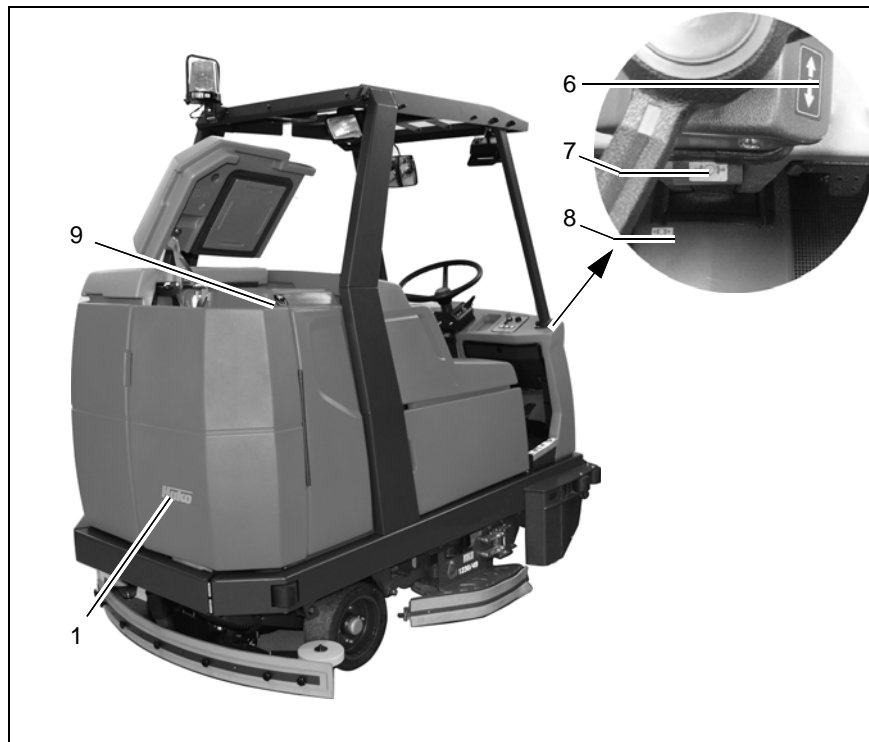
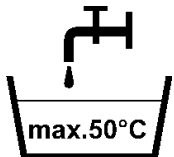

Fig. 2

Safety Information

Solution drainage

(Fig. 3/10)

The solution is drained via the hose which hangs to the left of this label.

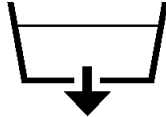

Waste water drainage

(Fig. 3/11)

The waste water is drained via the hose which hangs to the right of this label.

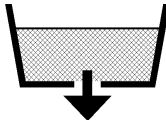

No waste water drainage

(Fig. 3/12)

The flap serves exclusively for cleaning and maintenance of the recovery tank.

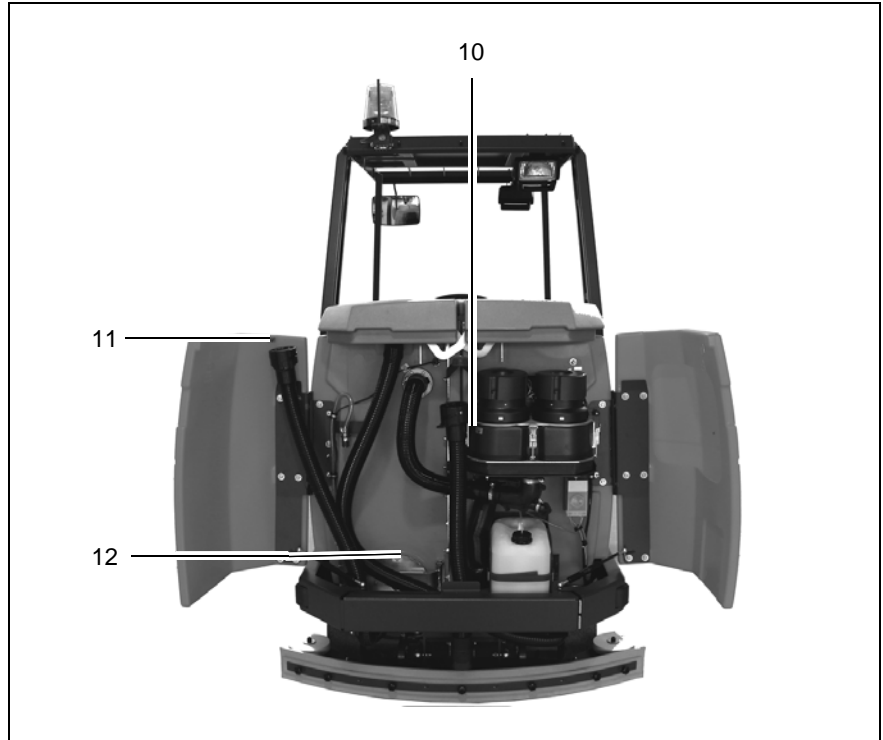

Fig. 3

Starting Up

2 Starting Up



Pay attention to persons in the vicinity of the vehicle when completing any work.

2.1 Instruction

Operators must receive instruction before the vehicle is put into service. Only technicians from your local authorized Hako dealer are allowed to provide initial instruction on the vehicle. The manufacturing plant will notify the dealer immediately after delivering the vehicle and the dealer will contact you to arrange a date.

2.2 Initial battery charge

An initial battery charge must be performed on the batteries in order for them to provide an optimum performance and service life. A battery charger is available which is specially adapted to the batteries.



Only use batteries and chargers recommended by us. The full terms of warranty can only be accepted when these units are used.



Before starting the vehicle up for the first time, the batteries to be used must be fully charged, properly, by implementing the initial battery charge routine. Hako assumes no liability for damage to the battery caused by a fault when the battery is charged for the first time.



The seat console must be pivoted open during the battery charging process to prevent the development of explosive oxyhydrogen!



Only use the original charger! Pay attention that the insulation is not initially damaged and not damaged during the charging process. The cable must not rub against anything. Do not use the charger if the insulation is damaged.



Do not inhale battery gases.

Please pay attention to the operating manual provided with the charging unit as well as the manual from the battery manufacturer. Powering up the batteries is described in such detail in the manufacturer's documents that further information on the subject is considered unnecessary for this manual.

Starting Up

2.3 Prior to starting up for the first time

The following work must be completed before starting the vehicle up for the first time:

2.3.1 Assembling and disassembling brushes and pads

The machine must have three brushes or three pads fitted.



Before starting to use the vehicle for the first time, ensure that appropriate brushes or pads have been installed.



Switch off the scrubbing unit, set the key switch to position 0 and remove the key.

Selecting brushes

The scrubber drier must be equipped with the brushes and pads from the accessories program according to the degree of soiling and characteristics of the floor.



Refer to Section 4 for the brushes available.

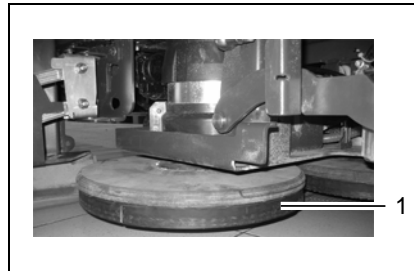

Fig. 4

At the factory, a water retaining ring (Fig. 4/1) is fitted to the brushes which reduces water consumption considerably during scrubbing.

Opening and closing the deflector

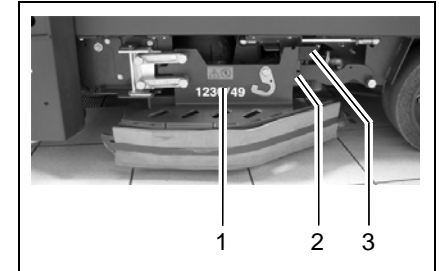

Fig. 5

- 1 Deflector
- 2 Deflector lock
- 3 Grip

Open the deflector (Fig. 5/1) before assembling or disassembling brushes and pads:

1. Take hold of the deflector (Fig. 5/1) by the grip (Fig. 5/3).
2. Raise the deflector (Fig. 5/1) and pivot outwards to the front.
3. Lower the deflector (Fig. 5/1) (service position).

The deflector is closed in the opposite sequence.

Starting Up

Assembly sequence

Assemble the middle brush or pad first and then mount the outer brushes / pads.

Disassembling sequence

The outer left brush or pad must be disassembled before the middle brush or pad can be disassembled.



Disassemble the middle brush or pad preferably from the left-hand side of the vehicle because the guiding aid for the assembly tool is located here.

Assembly tool

To simplify assembly and disassembly of the middle brush or pad in particular, an assembly tool (Fig. 6/4) is provided which is kept in a corresponding holder (Fig. 6/3) under the seat console which can be opened out.

Both sides of the plate (Fig. 6/1+6) of the assembly tool (Fig. 6/3) can be used:

- To assemble the brushes, the flat side of the plate (Fig. 6/1) must face upwards.
- To assemble the pads, the side of the plate with the dowels (Fig. 6/5) must point upwards (Fig. 6/6).



There are dowels (Fig. 6/2) on both sides of the plate which serve to center the brush or pad on the assembly tool.

Turn the plate:

1. Unscrew the socket screw.
2. Remove the plate (Fig. 6/1+6) from the dowels (Fig. 6/7).
3. Turn the plate (Fig. 6/1+6) around.
4. Fit the plate (Fig. 6/1+6) the other way around on the dowels (Fig. 6/7).
5. Screw in the socket screw.



The assembly tool can be used to assemble and disassemble all the brushes or pads.

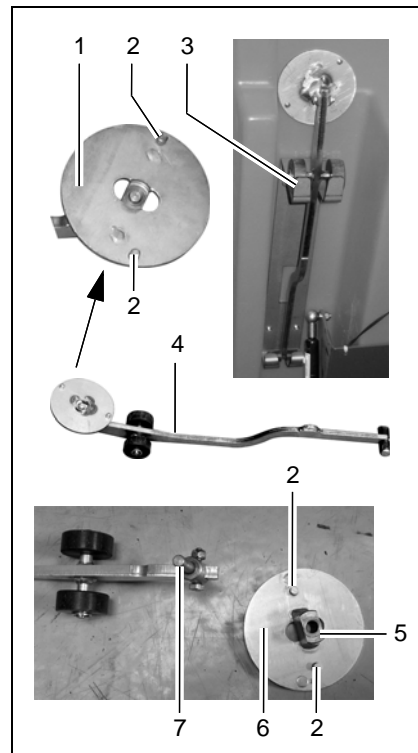

Fig. 6

Starting Up

Assembling the middle brush or middle pad

1. Open the deflector (Fig. 5/1), refer to Section "Opening and closing the deflector".
2. If necessary, remove the brushes or pads already installed, refer to Section "Disassembling the outer brushes / pads" and Section "Disassembling the middle brush or middle pad".
3. Position the middle brush (Fig. 7/2) or middle pad (Fig. 7/5) as illustrated in Fig. 7 on the assembly tool (Fig. 7/1).



The correct side of the plate of the assembly tool must point upwards, refer to Section "Assembly tool".

4. Take hold of the assembly tool (Fig. 7/1) at the narrow end and slide the brush (Fig. 7/2) or pad (Fig. 7/5) under the middle brush catch (Fig. 7/4).

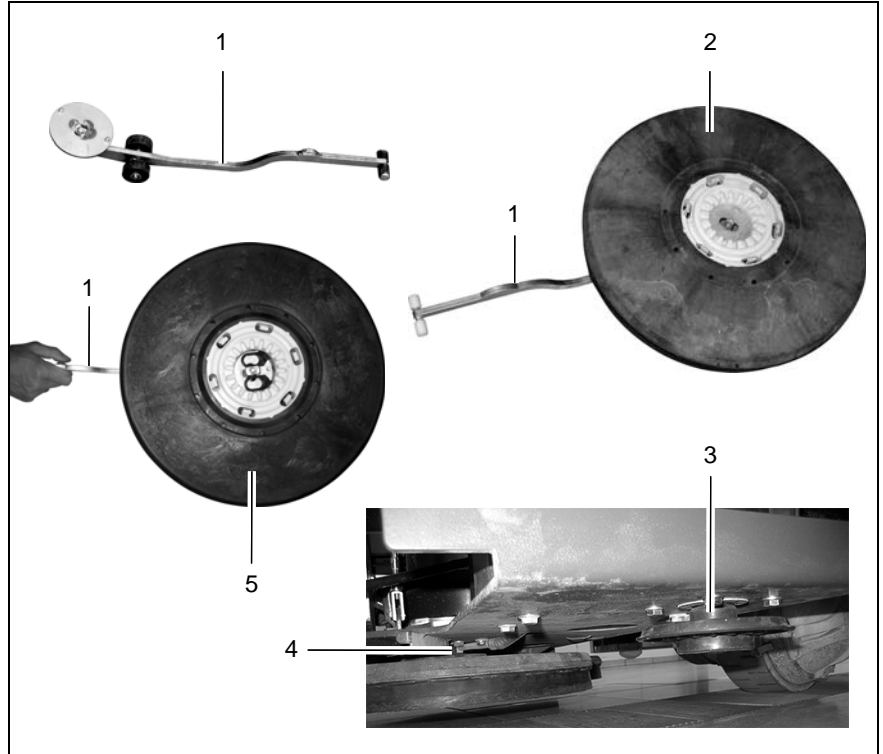

Fig. 7

Starting Up

- Force the narrow end of the assembly tool (Fig. 7/1) downwards. As a result of the levering effect, the brush (Fig. 7/2) or pad (Fig. 7/5) is pressed into the brush catch and audibly latches in place.
- In order to control whether all the hooks are in place, turn the brush or pad installed once.
- Continue by assembling the outer brushes, refer to Section "Assembling the outer brushes / pads".
- Close the deflector, refer to Section "Opening and closing the deflector". The deflector (Fig. 5/1) is now in its working position.

Assembling the outer brushes / pads

- Open the deflector (Fig. 5/1), refer to Section "Opening and closing the deflector".
- Slide the brush (Fig. 7/2) or pad (Fig. 7/5) under the brush head in accordance with Fig. 8.
- Raise the brush (Fig. 7/2) or pad (Fig. 7/5) and turn it slightly until the toothing meshes.

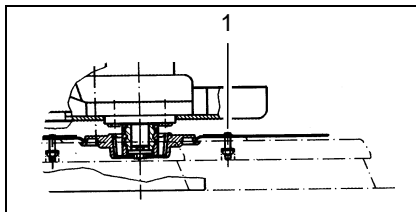

Fig. 8

- Pull the brush (Fig. 7/2) or pad (Fig. 7/5) up until all six hooks latch in the catches.
- In order to control whether all the hooks are in place, turn the brush or pad installed once.
- Close the deflector, refer to Section "Opening and closing the deflector". The deflector (Fig. 5/1) is now in its working position.



You can also use the assembly tool as an aid to complete steps 2 to 4, refer to the corresponding steps 3 to 5 in Section "Assembling the middle brush or middle pad". When completing Step 5, pay attention that you must simultaneously use your free

hand to push down on the brush head! Exerting counterpressure is the only way to ensure that the brush or pad engages properly!

Disassembling the outer brushes / pads

- Open the deflector (Fig. 5/1), refer to Section "Opening and closing the deflector".
- Pull the brush (Fig. 7/2) or pad (Fig. 7/5) from the brush head. Or:
- Slide the narrow side of the assembly tool between the brush/pad and brush head and press the wide end of the assembly tool downwards. As a result of the levering effect, the brushes / pads are released from the brush head (Fig. 7/3).

Starting Up

Disassembling the middle brush or middle pad



To simplify disassembling the middle brush, a guiding aid is provided on the left-hand side when facing the front of the vehicle.

1. Open the left-hand deflector, refer to Section “Opening and closing the deflector”.
2. Disassemble the outer left brush or pad, refer to Section “Disassembling the outer brushes / pads”.
3. Insert the narrow side of the assembly tool (Fig. 9/1) in the guiding aid (Fig. 9/2).
4. Slide the assembly tool (Fig. 9/1) as far as possible to the rear.
5. Force the wide end of the assembly tool downwards. As a result of the levering effect, the brush or pad (Fig. 9/3) is released from the brush head.
6. Draw the assembly tool (Fig. 9/1) back and remove from the guiding aid (Fig. 9/2).

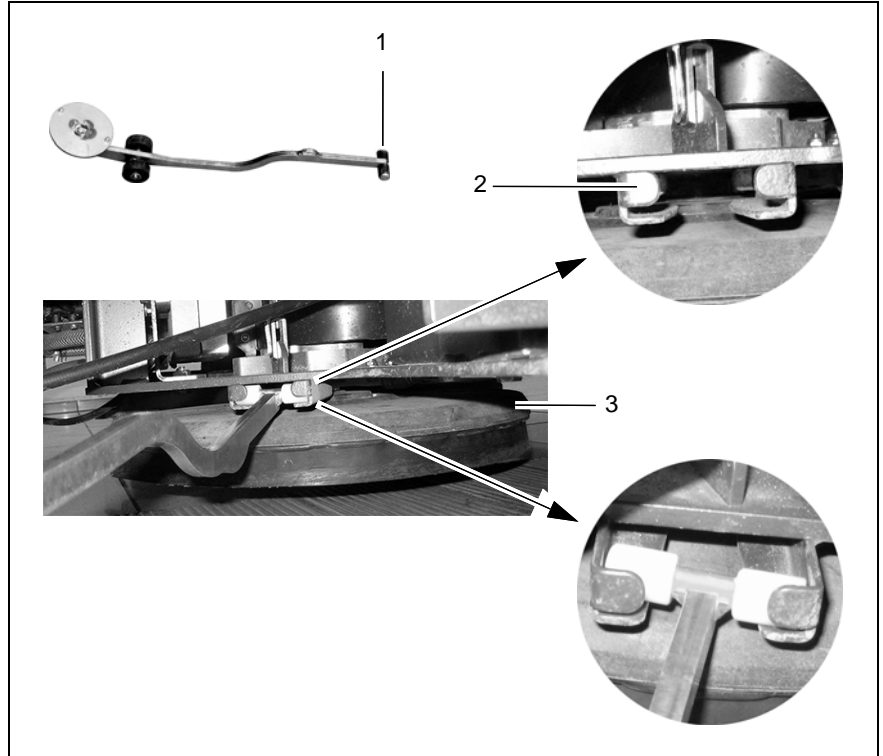

Fig. 9

Starting Up

2.3.2 Installing and adjusting the squeegee

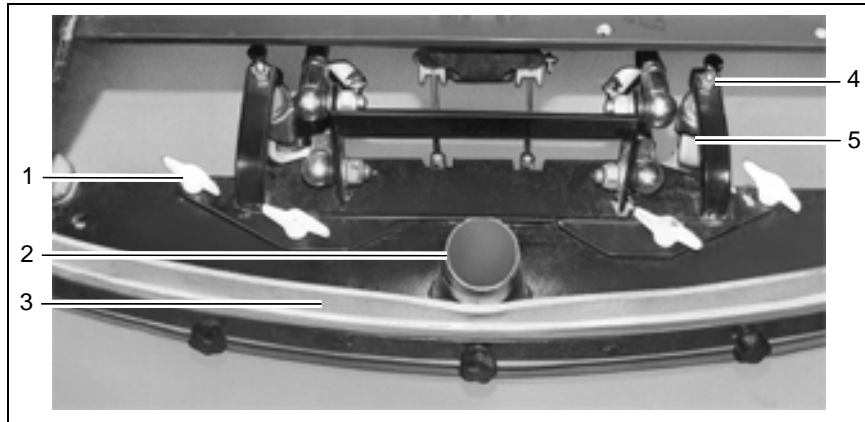

Fig. 10

Installing the squeegee

1. Switch on the key switch.
2. Lower the holding attachment of the squeegee: Press the button for the squeegee and suction turbine so that the green control lamp lights up.
3. Switch off the key switch and remove the key.
4. Open the rear doors.
5. Slide the squeegee from the rear under the lowered holding attachment and fix the squeegee to it with the four wing nuts (Fig. 10/1).
6. Attach the suction hose to the connection nozzle (Fig. 10/2) of the squeegee.
7. Insert the key in the key switch and turn the key switch on.
8. The squeegee is lifted automatically.
9. Close the rear doors.

Starting Up

Adjusting the squeegee

The squeegee must be set up on a level floor according to the conditions in which it is to be used. The squeegee must stand vertically on the floor (adjusted at the factory). The sealing strip (Fig. 10/3) should bend slightly to the rear when the vehicle is in operation. Supporting rollers (Fig. 10/5) limit its movement toward the floor. These support rollers must be adjusted in order to raise the contact surface of the squeegee:

- Loosen the conternuts (Fig. 10/4) and raise the supporting rollers on the left and right evenly (turn screw counterclockwise and lock again).

The sealing strip now bends a little more towards the rear. An adjustment of the supporting rollers is also necessary when the edge of the sealing strip is worn.

2.3.3 Adjusting the driver's seat

The driver's seat (Fig. 11) must be adjusted so that the driver is seated comfortably and can reach all the operating elements with ease.



The vehicle is equipped with a seat contact switch. The vehicle can only be operated when the operating person is seated on the seat.

The scrubber drier is equipped with a driver's seat which can be adjusted in a longitudinal direction (forward and back):

1. Press the lever on the right of the seat outwards slightly.
2. Slide the seat forward or back in steps of 15 mm.

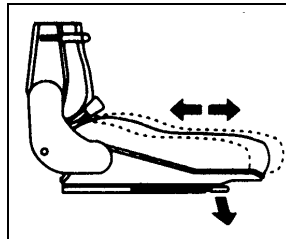

Fig. 11

Starting Up

2.4 Before starting up daily

Carry out the following checks before starting the vehicle up for its daily operation (also refer to Section 5.3.2):

1. Check the recovery tank, empty as necessary. Clean it as necessary. Refer to Sections 5.6.1 and 5.6.2.
2. Fill the solution tank and cleaning agent in accordance with the manufacturer's mixing directives. Refer to Section 3.1.4 and Section 5.5.1.



Only use cleaning agents (non-foaming) suitable for the vehicle's vendor. We recommend using our clean and care products which are specially balanced for the vehicles. These products meet the requirements stipulated in the German Washing and Cleansing Agent Act (WRMG - Wasch- und Reinigungsmittelgesetz).

3. Check the battery charge and recharge as necessary; refer to Section 5.4.1.



Before starting the vehicle for its first working operation, carry out an initial battery charging routine; refer to Section 2.2.

4. Check the parking space for signs of leaks. Hoses, lines and tanks must show no signs of leaks or damage. If necessary, clear up any defects before putting the vehicle into operation.

3 Operation



Operating personnel must read the operating manual through carefully. Operating personnel should complete their initial test drive on open ground or a test track until they are familiar with the individual operating elements and the respective functions.

3.1 Method of operation

The Scrubmaster B310 R is a scrubber drier for wet cleaning hard floors (refer to Fig. 12). It cleans floors by means of intensive scrubbing with the aid of a water and cleaning agent solution. The squeegee at the rear of the vehicle vacuums up the waste water into the recovery tank in the same working process.

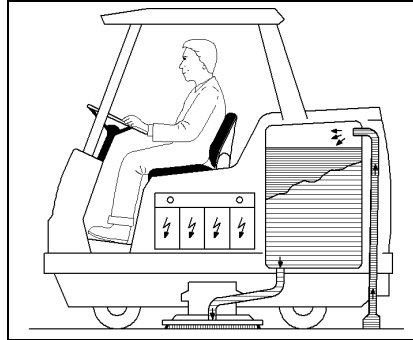

Fig. 12

The scrubber drier is a ride-on machine designed for the economic cleaning of large floor areas in buildings. A seat contact ensures that the vehicle can only be operated when an operator is seated on the driver's seat.

The most important vehicle elements are described below:

3.1.1 Scrubbing unit (Fig. 13/4)

Three circular brushes, which can be changed without the need of tools, ensure a high cleaning performance. They are each driven by a brush motor. The brush pressure can be adjusted electrically according to the floor and accumulation of dirt.

When the brushes are raised, the water supply and brush rotation are stopped automatically. The deflection bars to the left and right of the circular brushes can be raised, if necessary. This ensures the cleaning solution is not forced to the center of the vehicle and, as a result, can soak the dirt. This is necessary for basic cleaning (wet scrubbing only), for example. Hook in the deflectors, refer to Section "Deflector".



In the case of all cleaning work involving immediate vacuuming, the deflectors must be unhooked so that the deflectors make contact with the floor.

Operation

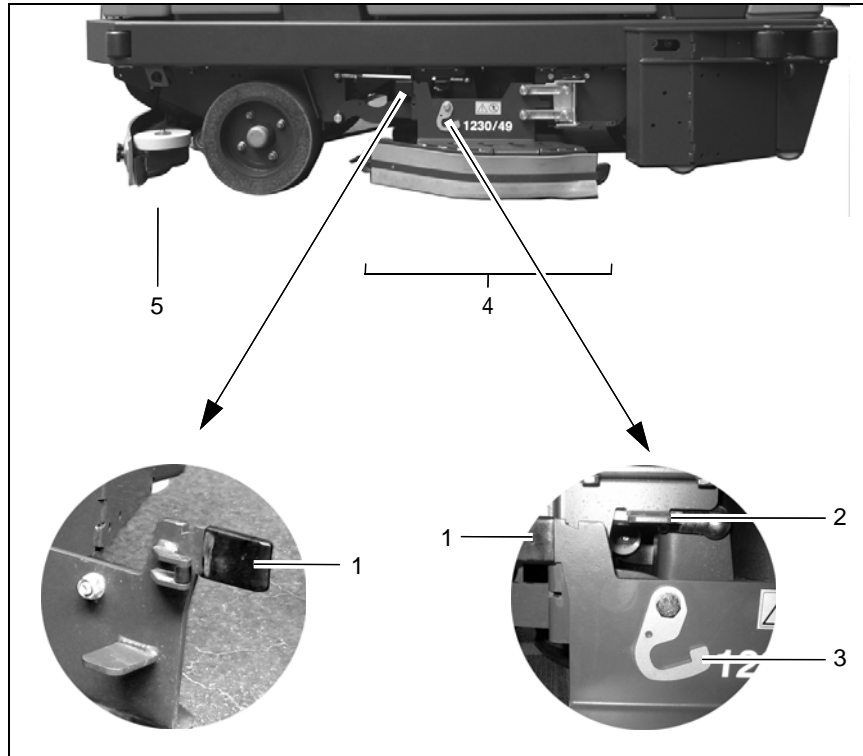

Fig. 13

Deflector

(Fig. 13/4)

To the right and left of the circular brushes, near the floor, are two deflectors which, when in their working position, prevent water splashing to the sides and guide the waste water to the center of the vehicle so that it can be vacuumed up better.

The deflectors can be raised, if necessary. This is the case for basic cleaning, for example, where the floor only needs to be scrubbed when wet and the solution is not vacuumed up but allowed to soak in instead. To raise the deflector, take hold of the grip (Fig. 13/1), raise it and hook the locking hooks (Fig. 13/3) in the recesses in the angle (Fig. 13/2) above it. Proceed in the same way on the other side of the side of the vehicle.

Operation

3.1.2 Squeegee (Fig. 13/5)

The squeegee, which projects at the sides, is fixed to the scrubber drier so that it can pivot and swing. This enables it to evade obstacles in the current track and pivot back. Its strong suction capacity ensures the waste water is vacuumed up fully even on uneven floor and in bends, leaving the floor dry enough to be walked on. The squeegee must be checked prior to starting work, when disposing of waste water and/or filling the solution tank and cleared of any foreign bodies which have been vacuumed up.

Check that the sealing strips are in perfect condition. The rollers serve to support the squeegee to prevent excessive bending of the sealing strips. The squeegee is automatically raised when reversing.

3.1.3 Suction turbines (suction) (Fig. 14/3)

The two suction turbines are located on the rear panel of the solution tank and can be accessed after opening the rear doors. The suction turbines are switched on and off automatically when lowering and raising the squeegee, respectively. A float switch in the recovery tank switches the suction turbine off automatically on reaching the maximum fill height.

3.1.4 Solution tank (Fig. 14/2)

The solution tank is located behind the driver's seat, on the right-hand side (when facing the front). The fresh water tank is a tank partitioned by a membrane panel and has a volume of approx. 296 liters. Open up the gray tank cap and secure it to fill the tank. Fill water, max. 50 °C, and add the cleaning agent in accordance with the manufacturer's instructions. Lower the cap again to close it.



Only use cleaning agents (non-foaming) suitable for the vehicle's vendor.

We recommend using our clean and care products which are specially balanced for the scrubber drier. These products meet the requirements stipulated in the German washing and cleaning agent directive (WRMG - Wasch- und Reinigungsmittelgesetzes). Observe the correct dosage of the cleaning agent. The correct dosage helps to reduce costs and protect the environment.

The development of excessive foam impairs the machine's function. It indi-

Operation

cates overdosage of the cleaning agent; components of the cleaning agent which are fed back to the waste water cause foaming. Information on dosage is provided on the cleaning agent container. Use the manufacturer's information as an initial guideline. Practical experience will ensure that you quickly find out which is the right cleaning agent and the optimum dosage to suit your needs.

The solution feed to the brushes is automatically opened when the scrubbing program is activated. If necessary, the feed can be stopped manually by means of the ball cock.

Operating times with one tankful:

- at 2 l/min. approx. 155 minutes
- at 4 l/min. approx. 77 minutes
- at 7 l/min. approx. 44 minutes

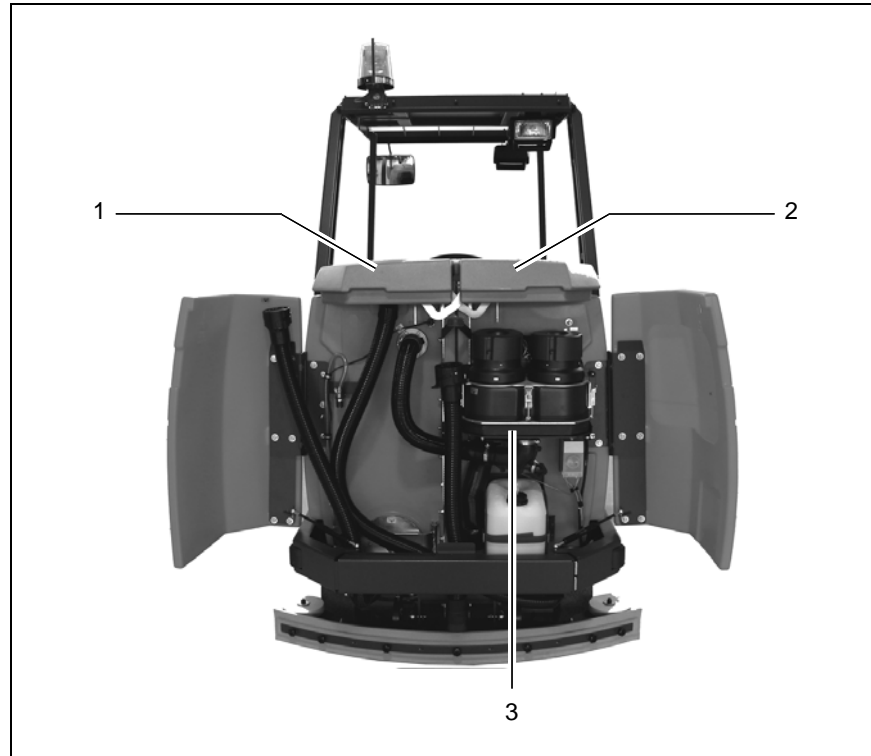

Fig. 14

Operation

3.1.5 Waster water tank (Fig. 14/1)

The waste tank is located on the left behind the driver's seat (looking towards the front). The waste water tank is a tank partitioned by a membrane panel and has a volume of approx. 296 liters. The waste water is fed to the waste water tank via the squeegee by means of a vacuum. A float switch at the top of the waste water tank switches the suction turbine off automatically as soon as the maximum tank fill level is reached. In this case, the control lamp (Fig. 19/2) on the left operating panel lights up. An acoustic signal is also issued. A vacuuming tool (refer to Section 4), which can be connected to the vehicle, is optionally available with which to clean and vacuum up water from areas difficult to access.

3.1.6 Traction drive

The traction drive is provided by a drive motor on the steerable front wheel. The driving speed can be continuously regulated via the accelerator by means of the electronic drive control (pulse contact control). The axle gear is a gear train running in an oil bath and is low-maintenance: No gear oil change is necessary.



In the case of faults involving the traction drive, stop the vehicle immediately and remove the key from the key switch!

3.1.7 Brakes

The scrubber drier is equipped with a service brake and a parking brake. The service brake relates to a drum brake which acts hydraulically on the rear wheels. It is actuated by a foot pedal. The parking brake is actuated mechanically via brake cables. It is applied by means of the foot pedal to the left of the steering column and released using the safety catch in the steering column.

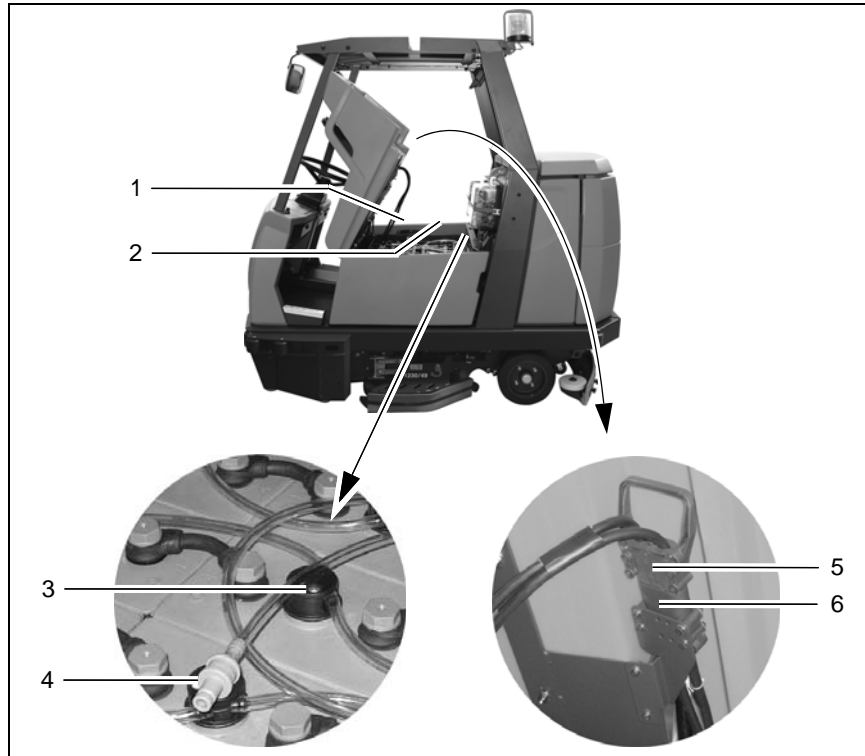

Fig. 15

3.1.8 Batteries and charger

The scrubber drier is powered by a traction battery (36 Volt/480 Ah₅). The battery is composed of 18 individual PzS cells. They are installed in a battery trough (Fig. 15/2). The advantage here is the quick and simple removal and installation processes using a fork-lift truck or lifting gear, particularly in multi-shift operation. The battery trough is provided with the necessary fitting holes (Fig. 15/1). The trough battery is provided with a battery water top-up system with fill level indicator (Fig. 15/3) for each individual cell and with automatic plugs (Fig. 15/4) to enable simple refilling of water.

To ensure protection against total discharge, the scrubber drier is equipped with a total discharge signal transducer (TSG). It is integrated in the electronic system and set up at the factory for PzS batteries (service indicator: No. 5).

Operation



If other batteries are used, the total discharge signal transducer must be adjusted. This adjustment work should only be performed at an authorized Hako service center.

The trough battery is provided with a connection cable with battery plug (Fig. 15/5). When the battery plug is plugged into the vehicle socket (Fig. 15/6), the vehicle is ready to operate. To charge the trough battery, insert the battery plug in the charger. The vehicle includes a battery charger providing

- 36 Volt/60 ampere
- IU1a characteristic curve
- 230 V power supply line

Pay attention to the safety information titled "Information on driving batteries", supplementary sheet 88-60-2556, enclosed with each battery.

Operation

3.1.9 Options

- 1 Working lights
- 2 Cab safety roof
- 3 Flashing beacon
- 4 Vacuuming tool
- 5 Side collision protection
 - 5a = left-hand side
 - 5b = right-hand side

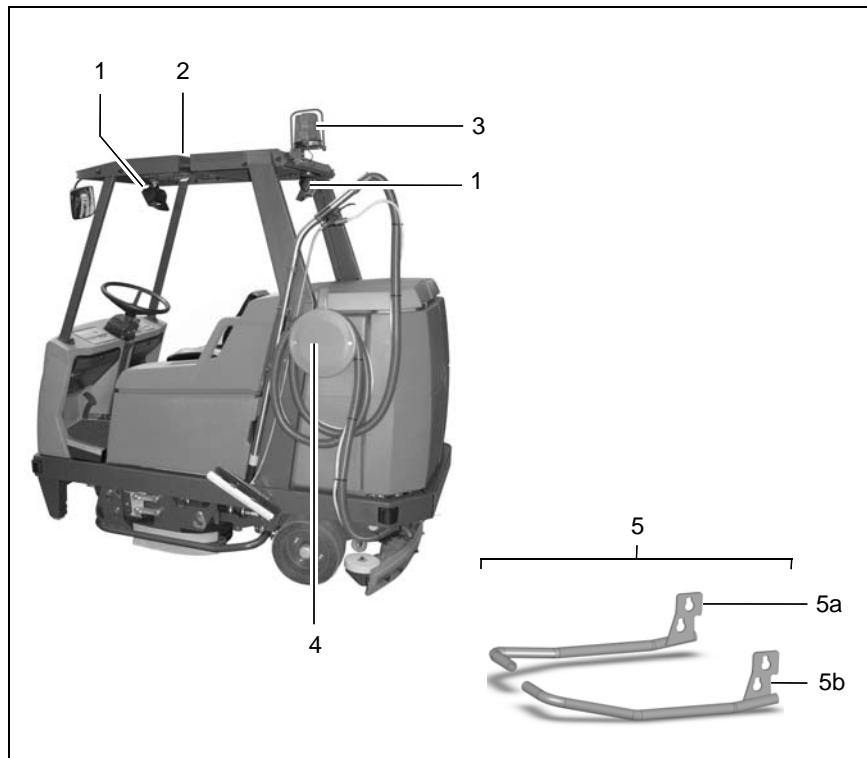

Fig. 16

Operation

The basic vehicle can be supplemented by further components. The order and spare parts numbers of these components are in brackets.

- **Working lights**

(Fig. 16/1) (7584.02)

Area of use: To enable use of the vehicle even in badly lit areas.

- **Cab safety roof**

(Fig. 16/2) (7582)

Area of use: To protect the driver, e.g. from parts which could fall from high rack warehouses.



Pay attention that assembly of a cab safety roof is made compulsory when the vehicle is operated in such risk areas.

- **Flashing beacon**

(Fig. 16/3)

(7585.02 Assembly on cab safety roof)
(7585.10 Assembly on pole / without cab safety roof)

Area of use: To improve awareness of the vehicle when in use.

Operation

- **Spraying/Vacuumping tool (Fig. 16/4)**

Area of use: For manual cleaning of areas which are difficult to access with spraying and vacuuming tools. A holder can be installed on the left hand side of the vehicle to fix the vacuuming tool. Two holes are already drilled in the left-hand side of the vehicle for this. The corresponding switch is provided on the right-hand operating panel to operate the vacuuming tool.



The parking brake must be actuated before putting the spray-vacuumping tool into operation, otherwise the spraying-vacuumping tool has no function!

The following belong to the spraying-vacuumping tool:

- **Floor scrubbing and vacuuming tool** (7009)
- **Suction and spraying hose** (7766)
- **Tool holder and attachment parts** (7311.10)

- **Hand-held vacuum cleaner (Fig. 16/4)**

Area of use: For vacuuming up water manually in areas which are difficult to access.

The hand-held vacuum cleaner can be fixed to the tool holder (refer to spraying-vacuumping tool).

The hand-held vacuum cleaner contains:

- **Adapter** to connect the following tools (7893)
- **Flexible plastic extension hose**, length: 3 m (7880)
- **Suction pipe** (for connection to the plastic extension hose), length: 1.3 m (7881)
- **Suction nozzle** with rubber lips (7883)

- **Side collision protection (Fig. 16/5)**

(7680.30)

The side collision protection consists of two steel bars which can be assembled on the right and left-hand sides of the vehicle at the height of the circular brushes and deflectors to protect the scrubber drier from damage cause by collisions. The side collision protection can be disassembled quickly, without the need of any tools.

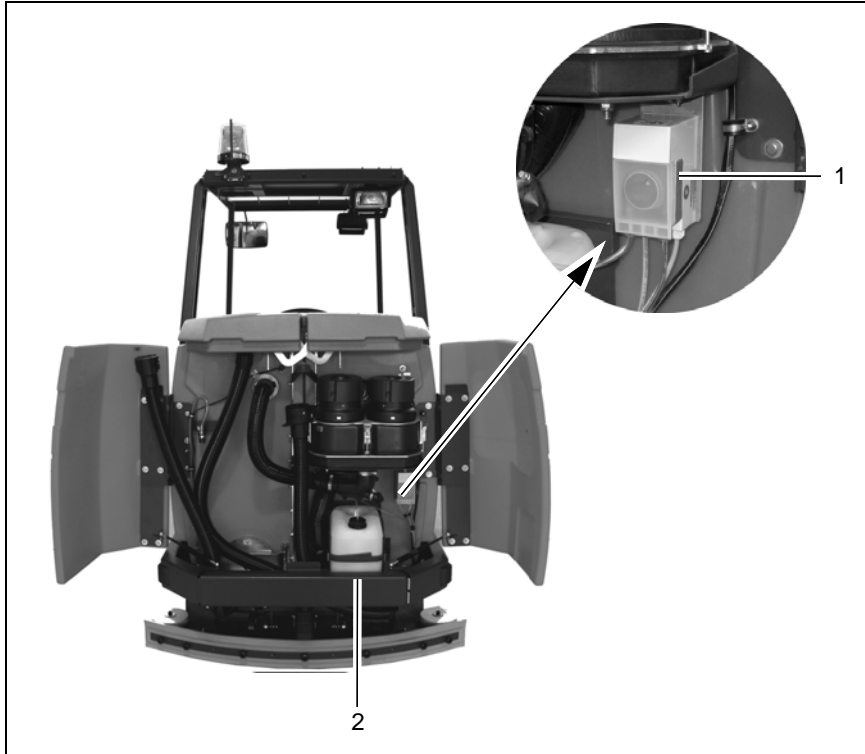

Chemical dosing system (Fig. 17/1) (7678.70)

The chemical dosing system adds a chemical cleaning agent to the fresh water. The chemical cleaning agent is in a canister (Fig. 17/2) and is not part of the scope of delivery of the chemical dosing system.

Fig. 17

Operation

3.2 Operating and indicator elements

3.2.1 Operating elements in the driver's cab

- 1 Left-hand operating panel
- 2 Steering wheel
- 3 Safety catch (to release the parking brake)
- 4 Accelerator to drive forwards or backwards
- 5 Service brake
- 6 Direction switch (forwards/reverse)
- 7 Right-hand operating panel
- 8 Parking brake

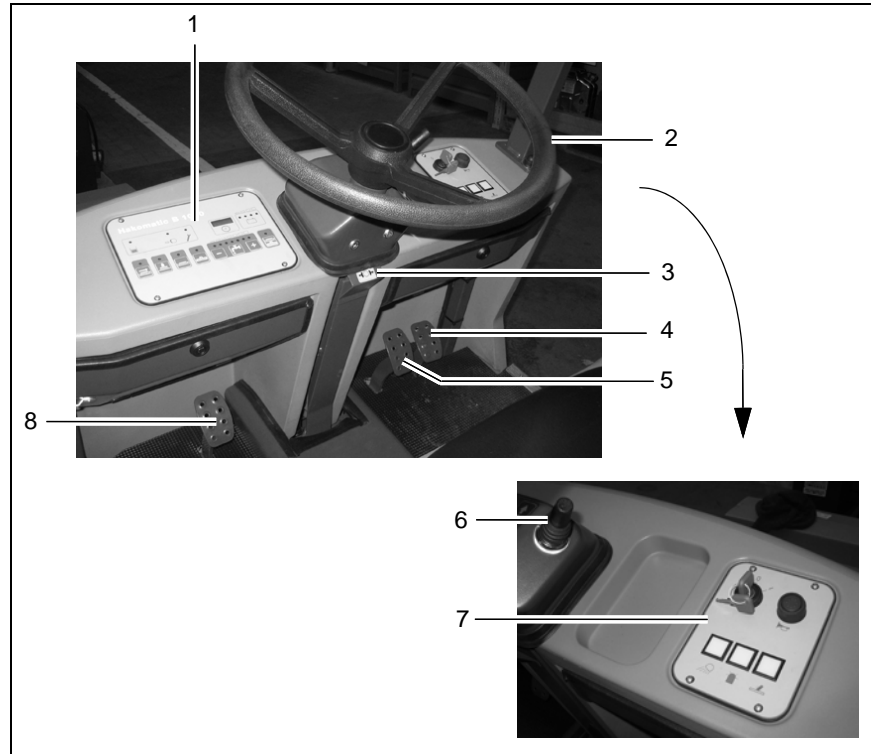

Fig. 18

Operation

Left-hand operating panel

(Fig. 18/1)

- This operating panel contains all the buttons for the electronically controlled standard cleaning programs.
- Individual functions can be added or removed from the cleaning process, as necessary.
- All the buttons are provided with clearly descriptive labels.
- The green control lamps in the operating buttons serve as function indicators.
- The significance and functioning method of the individual buttons on this operating panel is described in Section 3.2.2.

Steering wheel

(Fig. 18/2)

- The scrubber drier is steered by the steering wheel.

Safety catch

(Fig. 18/3)

- The safety catch serves to release the parking brake when applied.
- Operating sequence to release brake:
 - Tread on the pedal slightly.
 - Press the catch down.
 - Release the pedal.

Accelerator to drive forwards and backwards

(Fig. 18/4)

- The pedal on the right serves to control the driving speed (as in a normal vehicle).
- Before actuating the accelerator, use the driving direction switch (Fig. 18/6) to set the direction of travel: forwards or reverse.
- Forwards or reverse (according to the driving direction switch setting): Press the accelerator forward and down slowly.

- Release the pedal: The speed is automatically reduced, slowly. The vehicle rolls to a stop until reaching its zero setting.
- To stop securely, apply the service brake (Fig. 18/5).
- The speed for forward drive is approx. 8 kph and for reverse drive approx. 4 kph.
- The working speed with the brushes switches on and squeegee lowered is approx. 7.5 kph.



An acoustic warning signal (buzzer) is issued should the hydraulic motor overload. At the same time, the red alarm lamp (Fig. 18/4) lights up in the left-hand operating panel (Fig. 19/1) and the driving speed is reduced by approx. 50%. In addition, an error code appears in the service indicator (Fig. 19/5).

Operation

Service brake

(Fig. 18/5)

- In order to slow down the vehicle and bring the scrubber drier to a stop, tread on the foot pedal to the left of the accelerator (as with a normal vehicle) to actuate the hydraulic service brake.

Drive direction switch

(forwards/reverse)

(Fig. 18/6)

- It serves to select the driving direction:
 - Forward: control switch forward
 - Reverse: control switch back
 - Stop: control switch in center (neutral position)
- To change the driving direction, bring the machine to a stop by applying the service brake, select the new direction and accelerate again.

Right-hand operating panel

(Fig. 18/7)

- This operating panel contains the key switch to switch the vehicle on and off, the horn and three switches for the optionally available working lights, spraying/vacuuming tool and flashing beacon, also refer to Section 3.2.3.

Parking brake

(Fig. 18/8)

- The pedal to the left of the steering column serves to apply the parking brake to the rear wheels.
- When the parking brake is applied, the corresponding control lamp on the operating panel (Fig. 19/3) lights up red.
- If the driving direction switch is actuated while the parking brake is applied, a pulsating "beep" is issued.



Before getting out of the vehicle apply the parking brake, set the driving direction switch (Fig. 18/6) to its neutral position and switch the key switch to off.

Operation

3.2.2 Left-hand operating panel (Fig. 19)

- 1 Indicator field
- 2 Recovery tank indicator: When the control lamp is on (yellow), the maximum fill level has been reached.
- 3 Parking brake indicator: When the control lamp is on (red), the brake is applied.
- 4 Alarm indicator: When the control lamp is on (red), a functional fault has occurred.
- 5 Operating hour counter and service indicator
- 6 Battery and charge control indicator
- 7 (Key has no function)
- 8 Button for brush pressure
- 9 Button for brush drive
- 10 Button for squeegee and suction turbine
- 11 Buttons for controlling the fresh water supply
- 12 Button to reduce solution quantity
- 13 Button to switch fresh water supply on and off
- 14 Button to increase solution quantity
- 15 Green Hako button for simultaneous activation of scrubbing unit and vacuuming function

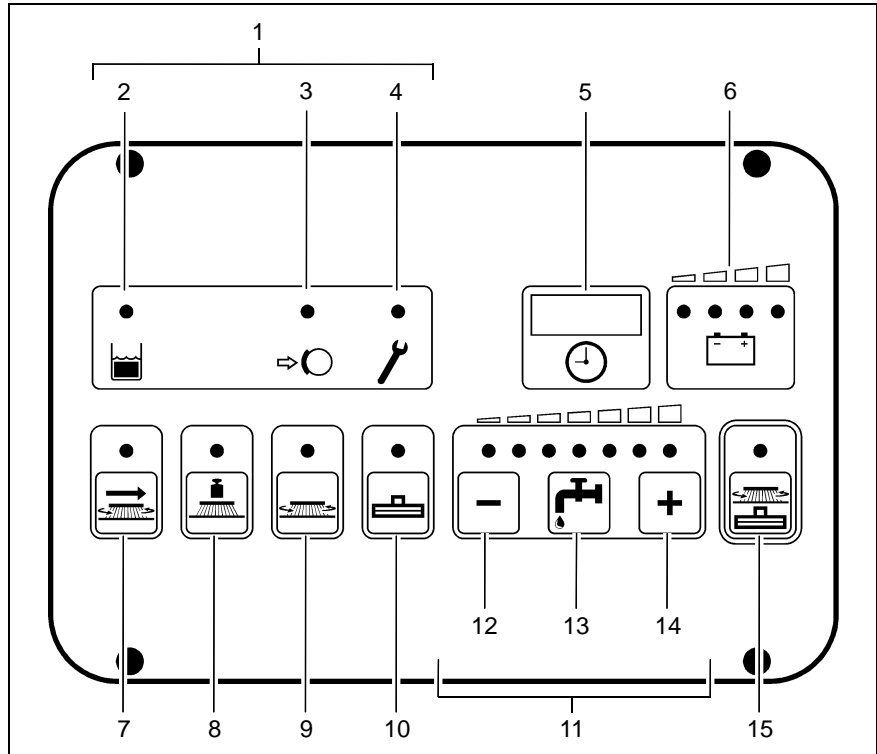

Fig. 19

Operation

Indicator field

(Fig. 19/1) The indicator field enables the scrubber drier to provide feedback on the operating status of the vehicle. This only relates to operating states which cannot be switched on and off via the operating panel: recovery tank full, parking brake applied and error message.

The individual buttons and functions are described in detail below:



Indicator for recovery tank maximum fill level

(Fig. 19/2) The yellow control lamp lights up when the recovery tank has reached its maximum fill level. Also, a "beep" signal is issued every 15 seconds. In this case, a float switch switches the suction turbine off and the squeegee is raised.



Indicator for parking brake applied

(Fig. 19/3) The control lamp lights up red when the parking brake has been actuated via the pedal to the left of the steering column. If the traction drive is switched on, an acoustic signal is also issued.



Indicator for function faults (Fig. 19/4)

The control lamp lights up red when one of the following faults occurs:

- The thermostatic switch disconnects from the brush or hydraulic motor.
- One of the safety fuses is defective or an electronic fuse has been tripped.
- Another fault has occurred.

At the same time, a four-digit code appears in the display of the service indicator (Fig. 19/5). This error code infers which fault has occurred (refer to Section 3.5.1). At the same time, the control lamps flash and an acoustic, pulsating signal is issued.

Operation

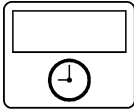

Operating hour counter

(Fig. 19/5) The four-digit LED serves to display the operating hours.

When the key in the key switch is turned on, one and then two four-digit codes appear in succession (for further details, refer to page 47, key switch (Fig. 20/1)). The operating hours appear after this.

The counter only operates when consumers are switched on (e.g. hydraulic or brush motor, suction turbine). At the same time, a red dot flashes at the bottom right of the display.

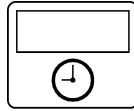

Service indicator

(Fig. 19/5) The same LED also serves for a more accurate determination of function faults.

If a fault occurs during operation, a four-digit code (error code) appears in the service indicator display. At the same time, the four dots of the error code flash in the display and a pulsating acoustic signal is issued. The control lamp indicating functional faults lights up red. Section 3.5.1 provides an overview of the error codes which help you clear functional faults yourself. Clear the fault before starting to use the machine again. If you cannot clear the fault yourself, note down the error code and inform the authorized Hako dealer responsible for your machine.

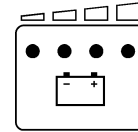

Battery and charge control indicator

(Fig. 19/6) After switching on the key switch, all four lamps light up when the battery is fully

charged. As the battery is discharged during operation, the three right-hand lamps indicate the level of discharge by going out in sequence from right to left. When the left, red lamp flashes, it indicates that work must come to an end. Approximately three minutes later, the brushes will return to their home position. After a further three minutes, the suction turbine is deactivated and the squeegee is raised. When the red lamp lights up continuously, approximately one minute remains until the entire vehicle shuts down automatically.



Drive back to the charger in good time. Take the distance to the charger into account.

Operation



Button for brush pressure

(Fig. 19/8) This button is used

to increase the brush pressure. This may be necessary when the area to be cleaned is extremely dirty. The pressing force can be increased to max. 93 kg. If the function is active, the green control lamp lights up.



Working with an increased brush pressure also means increased brush wear.

Therefore, only press this button when necessary.

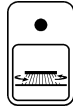

Button for the brush drive

(Fig. 19/9) This button serves

to switch the brushes and solution feed on and off with simultaneous, respective lowering and raising of the brush head. If the function is active, the green control lamp lights up.



Button for squeegee and suction turbine

(Fig. 19/10) This button serves

to switch the suction turbine on and off with simultaneous lowering and raising of the squeegee. If the function is active, the green control lamp lights up.



This button must also be pressed when working with optional tools connected to a suction hose. Operating personnel must not be seated on the driver's seat in this case (seat contact is bypassed). Only the suction turbine is activated at this point, the squeegee remains raised.

Operation

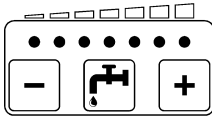

Buttons controlling the solution supply (Fig. 19/11)

The solution consumption used during cleaning can be regulated in seven stages. Accordingly, there are seven green control lamps on the keypad. Each lamp relates to one stage. The maximum quantity which can be used for cleaning is 7.14 l/min (all seven lamps are on). The minimum quantity is 1.38 l/min (only the left lamp is on). The last solution quantity selected is always used. When the scrubbing program is switched on for the first time, a solution quantity of approx. 3.5 l/min is automatically set.



Button to reduce solution quantity (Fig. 19/12)

The button serves to reduce the solution quantity supplied to the brushes. The solution quantity can be reduced in seven stages (see above). The selected stage remains programmed (last station memory) even if the machine is switched off temporarily.



Button to switch the solution supply on and off (Fig. 19/13)

This button serves to switch the solution feed on and off when the brush head is lowered. The solution quantity previously set remains unaltered (last station memory).

Operation



Button to increase solution quantity

(Fig. 19/14) The button serves to increase the solution quantity supplied to the brushes. The solution quantity can be increased in seven stages (see above). The selected stage remains programmed (last station memory) even if the machine is switched off temporarily.



Green Hako button for simultaneous activation of scrubbing unit and vacuuming function

(Fig. 19/15) After pressing the green Hako button, the most important basic functions for standard cleaning are automatically activated/deactivated in the correct sequence of use: suction turbine, brush rotation, solution feed and lowering or raising the brushes and squeegee. When the vehicle is ready for use in accordance with requirements, it can be set into operation simply and quickly by pressing the Hako button. When the Hako button has been pressed, the green control lamp lights up.

3.2.3 Right-hand operating panel (Fig. 20)

- 1 Key switch
- 2 Horn
- 3 Switch for spraying/vacuuming tool
- 4 Switch for flashing beacon
- 5 Switch for working lights

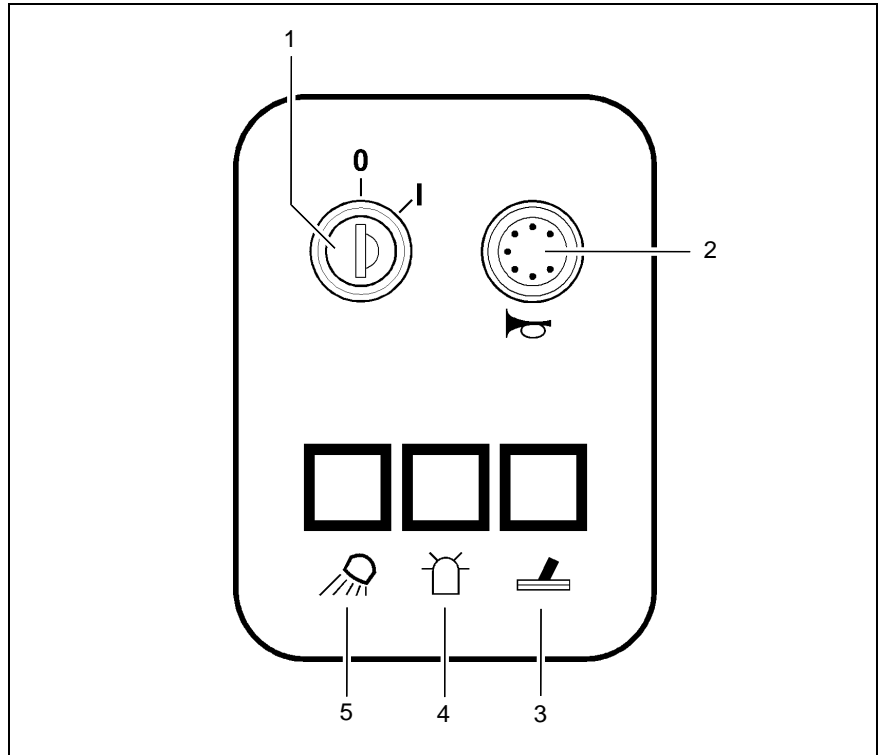

Fig. 20

Operation

Key switch

(Fig. 20/1)

It serves to switch the electrical installations on and off and to secure the vehicle against unauthorized use.

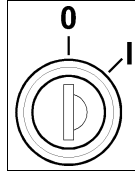

When the key switch is switched on (lock position 1), the following appear in the operating hour counter display (left-hand operating panel, refer to paragraph "Operating hour counter" in Section 3.2.2):

1 Software version

Displayed for approx. 1 second.

Example:

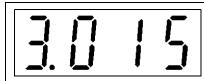

2 Error code

of the last fault which occurred, displayed for approx. 2 seconds. The display serves as information for the service technician so that the fault can be cleared quickly. For an overview of the error codes, refer to Section 3.5.1.

Example:

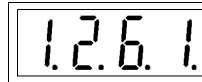

When a functional fault actually occurs, an acoustic signal is also issued and the red control lamp on the alarm indicator (Fig. 19/4) lights up.

3 Operating hour indicator

Continual display.

Example:

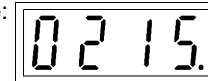

During operation, the dots flash in the display.

4 Control digits (optional)

In the case of brand new vehicles, it is possible that after switching on the key switch, this display also appears:

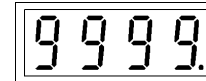

The control digits are for internal control purposes. The display changes to zero operating hours after one hour at the latest. The scrubber drier is ready for use while this display appears. The alarm indicator is activated.

Operation

Horn

(Fig. 20/2)

An acoustic warning signal is issued on actuating the horn knob.

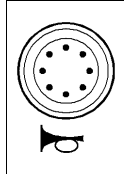

Switch for spraying/vacuuming tool

(Fig. 20/3)

This switch switches the vacuuming tool on or off. The suction tool is an optional accessory. If it is not installed, the switch has no function.

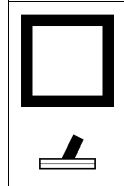

Switch for flashing beacon

(Fig. 20/4)

The flashing beacon is an optional accessory. If no flashing beacon is installed, the switch has no function.



Switch for working lights

(Fig. 20/5)

This switch switches the working lights on or off. This occurs even without the key switch being turned on.

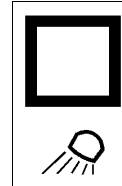

The working lights are optional accessories. If no working lights are installed, the switch has no function.

Operation

3.2.4 Operating elements on the machine

- 1 Opening between the waste and fresh water tank.
- 2 Filter sieve
- 3 Solution tank filling neck
- 4 Lid lock
- 5 Cover, recovery tank
- 6 Cover, solution tank
- 7 Right-hand rear door
- 8 Rear panel frame
- 9 Left-hand rear door
- 10 Solution draining hose
- 11 Waste water draining hose
- 12 Rear panel frame lock

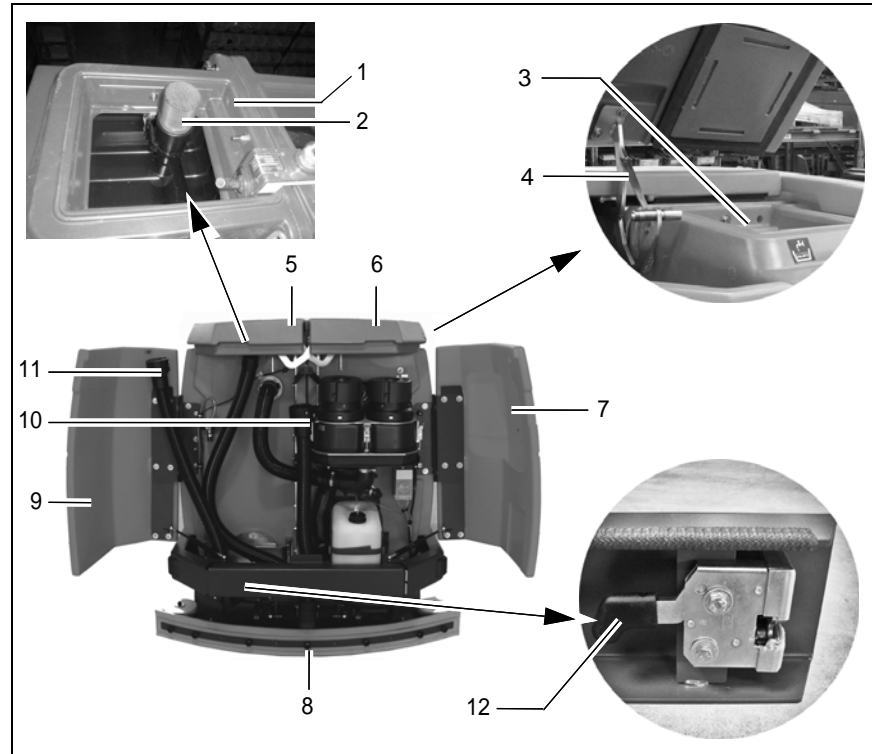

Fig. 21

Operation

Recovery tank

(Fig. 21/2+5)

The waste water filter (Fig. 21/2) is located under the recovery tank lid (Fig. 21/5) at the top of the recovery tank and is connected to the end of the suction pipe. It filters large particle dirt from the waste water and must be inspected or cleaned daily, refer to Section 5.6.4.

Solution tank

(Fig. 21/3+6)

In order to fill fresh water and cleaning agent, pivot up the lid of the fresh water tank (Fig. 21/6) and lock it. The tank is filled through the filling neck (Fig. 21/3), refer to Section 5.5.1.

Lid lock

(Fig. 21/4)

The lock prevents the lid falling shut. To lock the lid, move the bar and latch in place. The lid lock functions in the same way on the solution tank and recovery tank.

Rear doors

(Fig. 21/7+9)

Open the rear doors to access the draining hoses for waste water and solution.

Waste water draining hose

(Fig. 21/11)

The draining hose for waste water hooked is in the left-hand rear door. Only drain off waste water through this hose at an appropriate location, refer to Section 5.6.1.

Solution draining hose

(Fig. 21/10)

The draining hose for solution hangs to the left of the suction turbines. Only drain off the solution through this hose at an appropriate location, refer to Section 5.5.2.

Rear panel frame

(Fig. 21/8+12)

In order, for example, to access the flap to clean the recovery tank, the rear panel frame must be opened. To do this, pull the lock lever (Fig. 21/12) up and open the unlocked rear panel frame (Fig. 21/8).

Operation

- 13 Seat console
- 14 Electrical compartments
- 15 Side door
- 16 Battery trough

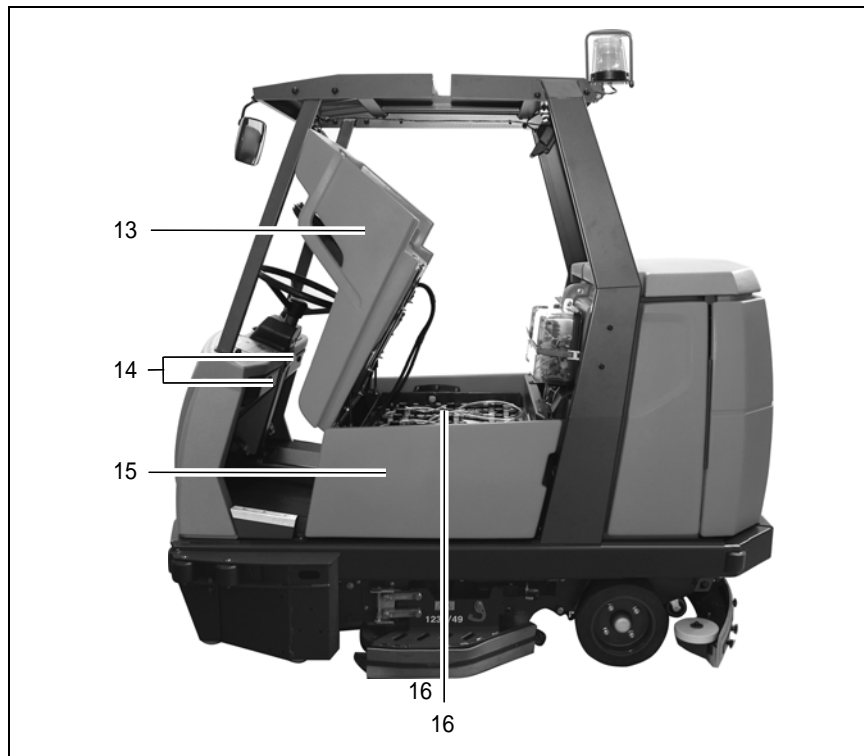

Fig. 22

Seat console

(Fig. 22/13)

The driver's seat is mounted on the seat console. The seat console can be pivoted up using the handle in order to access the batteries and electric system.

Electrical compartments

(Fig. 22/14)

In the driver's cab, to the left and right of the steering column, are two electrical compartments which must be opened by means of a special square wrench.



The electrical compartments are not provided in the sense of glove compartments.

Side door

(Fig. 22/15)

The side doors are located to the left and right of the trough battery. The doors must be pivoted open in order to change the battery trough, refer to Sections 5.4.3 and 5.4.4.

Battery trough

(Fig. 22/16)

The battery trough contains the 18 individual battery cells and serves to enable a quick change of battery. The battery trough is provided with fitting holes in order to be able to change it using suitable tools, also refer to Sections 5.4.3 and 5.4.4.

Operation

3.3 Operation

The scrubber drier can be operated on surfaces with a gradient of 6% for maximally 5 minutes.



Adapt your driving style to the local conditions (floor characteristics, persons in the vicinity, obstacles etc.).

3.3.1 Switching the machine on



Please read Section 1 before switching the vehicle on.

Carry out the following steps so that the machine is ready to operate:

- Disconnect the battery plug from the charger and connect it to the vehicle.



When connecting the battery plug to the vehicle, switch the key switch to off (lock position 0) beforehand.

- The vehicle is equipped with a safety shutdown via a seat contact (dead man's switch). This means that it is essential for operating personnel to be seated in the driver's seat to be able to operate the vehicle.
- Ensure that the driving direction switch is in its neutral setting, refer to accelerator for driving forwards and backwards in Section 3.2.1.

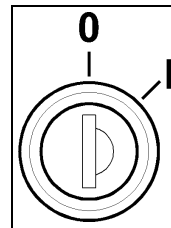

Fig. 23

- Actuate the service brake with your foot in order to prevent accidentally accelerating the vehicle, refer to Service Brake in Section 3.2.1.
- Insert the key in the key switch (Fig. 23).
- Turn the key from lock position 0 to position 1. The vehicle is ready to operate.

Operation

3.3.2 Accelerating

- Set the required driving direction with the direction switch: set the switch to the front to drive forward, set the switch to the rear to reverse.
- Release the parking brake, refer to Safety Catch in Section 3.2.1.
- Press the accelerator down slowly with your right foot until you reach the required driving speed.

3.3.3 Stopping and parking

- Remove your right foot from the accelerator to slow down. When the foot is fully removed from the accelerator, the vehicle rolls to a stop.
- Now press the right foot on the service brake pedal to stop the vehicle and bring it to a stop.
- Turn the key in the key switch counterclockwise to lock position 0 and remove the key.
- Press the left foot on the parking brake pedal to park the vehicle.



Always apply the parking brake and remove the key before getting out of the vehicle!

3.3.4 Cleaning

There are four cleaning programs available for selection:

1. Wet scrubbing and vacuuming dry
2. Wet scrubbing (basic cleaning)
3. Vacuuming dry
4. Vacuuming with the hand-held suction hose (option) / Working with the additional spraying/vacuuming tool.

The cleaning programs are activated via the left-hand operating panel, refer to Section 3.2.2. Press the relevant button as soon as the scrubber drier is ready to operate (see above).

Operation

Wet scrubbing and vacuuming dry

This program is the standard cleaning program for this vehicle.

- Press the green Hako button (Fig. 19/15) on the left-hand operating panel.



Various functions can be switched on or off with the following buttons according to the conditions at the location of use:

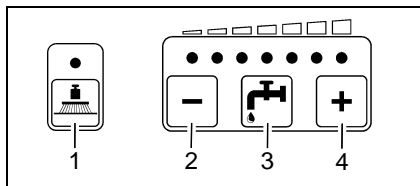

Fig. 24

- Increase brush pressure (Fig. 24/1)
- Reduce solution quantity (Fig. 24/2)
- Increase solution quantity (Fig. 24/4)
- Solution feed on/off (Fig. 24/3)



Check whether the floor is sufficiently dry at regular intervals, otherwise people could slip. If the floor is excessively wet, check the vehicle for leaks and that the sealing strips are in a good condition. If the sealing strips are damaged, change them; refer to Section 5.8.4.

Wet scrubbing (basic cleaning)

If you do not want to vacuum the floor dry in the same working procedure because you want the solution to soak into the dirt, for example, activate this program.



Wet floors are a potential risk for slipping! Ensure to provide the corresponding information and warning signs.

- Press the “Button for the brush drive” button (Fig. 19/9) on the left-hand operating panel.



Various functions can be switched on or off with the following buttons according to the conditions at the location of use:

- Increase brush pressure (Fig. 24/1)
- Reduce fresh water quantity (Fig. 24/2)
- Increase fresh water quantity (Fig. 24/4)
- Solution feed on/off (Fig. 24/3)

Operation

Vacuuming dry

- Press the “Button for squeegee and suction turbine” button (Fig. 19/10) on the left-hand operating panel.



Check whether the floor is sufficiently dry at regular intervals, otherwise people could slip. If the floor is excessively wet, check the vehicle for leaks and that the sealing strips are in a good condition. If the sealing strips are damaged, change them; refer to Section 5.8.4.

Vacuuming with the hand-held suction hose

The hand-held suction hose is an optional accessory. Vacuuming with the hand-held suction hose only works when the operator is not seated on the driver's seat (seat contact switch is not actuated) and the parking brake is applied.



Always apply the parking brake before getting out of the vehicle!



The parking brake must be actuated before putting the spray-vacuuming tool into operation, otherwise the spraying-vacuuming tool has no function!

- Press the “Button for squeegee and suction turbine” button (Fig. 19/10) on the left-hand operating panel.



The squeegee remains raised.

Useful tips for cleaning

- Sweep the floor before starting wet cleaning. This not only improves the cleaning effect but also reduces the machine's liability to wear.
- The floor should be treated twice in the case of particularly dirty floors or to remove wax (basic cleaning).
 - During the first cleaning process, the floor is scrubbed with a cleaning agent dosage appropriate to the degree of soiling, whereby the squeegee is raised.
 - Let the cleaning solution work into the floor for 5 to 10 minutes according to the manufacturer's information.
 - Then scrub the floor again with the squeegee lowered.
- Observe the correct dosage of the cleaning agent. Information on dosage is provided on the cleaning agent container.
- Use the manufacturer's information as an initial basis. Practical experience will ensure that you quickly find out which is the right Hako cleaning agent and the optimum dosage to suit your needs.

Operation



The correct dosage helps to reduce costs and protect the environment.



The development of excessive foam impairs the machine's function.

- Cause: Too much cleaning agent leads to certain component parts of it getting into the waste water resulting in the development of foam. This indicates that the amount and mixture of solution do not match the level of dirt.

3.3.5 Switching the machine off

- Turn the key from position 1 to lock position 0. The machine is no longer ready to operate.
- Remove the key from the key switch.



Apply the parking brake!

3.3.6 Loading and transporting the vehicle

Refer to Section 5.12.

Operation

3.4 After finishing work

1. Drive to a suitable service or parking area.



An appropriate service and parking area must have a solid floor, have a roof and ensure that no hazardous substances (e.g. oils, battery acid, cleaning agents, etc.) can get onto the floor or in the sewage system.

2. Stop the machine and switch it off.



Before getting out of the vehicle apply the parking brake, switch off the key switch and remove the key.

3. Empty and clean the recovery tank, refer to Sections 5.6.1 and 5.6.2.



Observe the applicable laws and local regulations when disposing of cleaning agents.

4. Check the fresh water filter, refer to Section 5.5.4.
5. Check the sealing strips and suction hose, refer to Section 5.8.
6. Check the electrical equipment, functions and settings.
7. Clean the vehicle, refer to Section 5.11.



It is not permitted to clean the vehicle with a pressure washer or steam blaster.

8. Charge the batteries, refer to Section 5.4.1.



The seat console must remain open during the charging process (otherwise there is a risk of oxyhydrogen developing).



If the machine is to be shutdown for a longer period, the solution tank must be emptied.

Operation

3.5 Function faults



The following applies when locating and clearing faults: Switch the vehicle off, remove the key from the key switch and disconnect the battery plug!

3.5.1 Error code table

In the case of system errors, a four-digit error code appears in the left-hand operating panel in addition to the service indicator (wrench symbol).

The dots in the error/service code flash. Clear the fault or note down the error/service code and inform your authorized Hako dealer.

Error code	Fault	Cause	Solution
1.2.5.2.	Brushes remain stopped because the thermostatic switch has been tripped.	The motor has overheated; foreign bodies have possibly jammed between the brush and shaft (e.g. tape and such).	<ul style="list-style-type: none"> • Check the brushes for foreign bodies and remove them, as necessary. • Allow the motor to cool down. • If the problem reoccurs, determine the cause of overheating; contact an authorized Hako service center, if necessary.
1.2.6.1.	Brushes remain stopped because the anti-blocking system has been tripped.	Foreign bodies (e.g. tape or such) block the brush.	<ul style="list-style-type: none"> • Check the brushes for foreign bodies and remove them, as necessary.
1.2.6.3.	The brush attachment and brush motors have been switched off because the anti-blocking system has been tripped.	Foreign bodies between the brush head and vehicle.	<ul style="list-style-type: none"> • Check the brush head for foreign bodies and remove them, as necessary.
1.4.6.1.	Squeegee holding attachment has been switched off because the anti-blocking system has been tripped	<ul style="list-style-type: none"> • Foreign bodies between the squeegee and vehicle. • Squeegee is jammed 	<ul style="list-style-type: none"> • Check the squeegee attachment for foreign bodies and remove them, as necessary • Free the squeegee.

Table 1

3.5.2 Other function faults

The vehicle does not work

Check the fuses, refer to Section 5.10.3.



In the event of faults in the traction drive, stop the vehicle immediately, apply the parking brake and remove the key!

Technical Data

4 Technical Data

Dimensions		
Vehicle length (with brush head and squeegee)	cm	215
Vehicle height, without/with cab safety roof	cm	140/200
Vehicle width	cm	133
Working width		
Brush head	cm	123
Squeegee	cm	126
Area coverage		
Theoretical at 7.5 kph	m ² /h	9225
Weights		
Dead weight (without driving batteries, without options, without driver)	kg	770
Total weight operational wet (with cab safety roof, without driver)	kg	1670
Gross total weight	kg	1820
Transport weight: Including driving batteries, without options, without solution, without driver	kg	1328

Technical Data

Axle loads		
Ready to use, front	kg	692
Ready to use, rear	kg	978
Driving performance		
Driving speed, forwards/reverse	kph	8.0/4.0
Working speed, maximum, forwards	kph	7.5
Climbing capacity, drive mode (max. 1 min)	%	15
Climbing capacity, work mode (max. 5 min)	%	6
Turning circle diameter, outer	M	3.35
Turning in aisle: minimum aisle width	M	2.40
Operating time with one battery charge	H	Approx. 3.4
Traction drive		
Drive motor (P2)	W	1400

Technical Data

Axles and wheels		
Wheelbase	cm	115
Gauge, rear	cm	88
Front wheel, diameter/width	mm	300/100
Rear wheel, diameter/width	mm	310/120
Specific wheel pressure at permissible gross total weight, front/rear	N/mm ²	1.36/1.05
Tightening torque of wheel nuts on rear wheels	Nm	140
Brakes		
Service brake:		Hydraulic
Drum brakes at rear, with automatic adjustment: diameter/width	mm	180/40
Brake fluid (e.g. ATE)	l	0.3
Parking brake:		
Cable brake at rear, adjustable: diameter/width	mm	180/40
Tank volume		
Membrane panel tank: fresh/waste water	l	296/296
Flow rate, adjustable from/to	l/min.	1.38/7.14

Technical Data

Brush head		
No. of brushes	Piece	3
Brush diameter	cm	43
Brush speed	rpm	210
Brush motor output (P2)/speed	W/rpm	2 x 710
Brush pressure, normal/increased	kg	68/93
Specific contact pressure normal/increased	N/cm ²	0.21/0.29
Suction turbines		
Power consumption/speed	W/rpm	635/13867
Air flow rate	m ³ /h	240
Vacuum	mbar (mm WS)	203 (2030)
Electrical installation		
Power supply	VDC	36
Type of current		DC
Nominal power, total	W	6300
Protection class	VDE 0700	III
Battery compartment: length/width/height	mm	760/610/465

Technical Data

<p>Noise emission value</p> <p>The sound power level ($L_{WA(d)}$) measured according to EN 60335-2-72 under normal under working conditions is:</p> <p>The sound pressure level (L_{pA}) measured according to DIN EN 60335-2-72 (at the driver's ear) under normal working conditions is:</p> <p>Inaccuracy factor (K_{pA}):</p>	<p>dB (A)</p> <p>dB (A)</p> <p>dB (A)</p>	<p>90</p> <p>76.5</p> <p>2</p>
<p>Vibration</p> <p>The weighted, effective value of the vibration, established in accordance with ISO 5349-1 to which the upper limbs (hand-arm) are exposed under normal working conditions is:</p> <p>The weighted, effective value of the vibration and shock, established in accordance with ISO 2631-1, to which the body (feet and seat area) is exposed under normal working conditions is:</p>	<p>m/s²</p> <p>m/s²</p>	<p>< 2.5</p> <p>< 0.5</p>

Technical Data

Special equipment:		
Driving batteries Traction battery, 18 cells, cell type 80 PzS Weight Dimensions: length/width/height	Order number V/Ah ₅ kg mm	4202 36/480 550 750/610/462
Battery charger Power supply Charge output Charging time	Order number VAC V/A H	4001.02 230 36/60 12
Cab safety roof (including rear-view mirror)	Order number	7582
Side collision protection	Order number	7680.30
Working lights (2 pieces)	Order number V/W	7584.02 2 x 24/70
Flashing beacon For installation on the cab safety roof For installation on a pole (when no cab safety roof is available)	V Order number Order number	36 7585.02 7585.10

Technical Data

Special equipment:		
Brushes (total of 3 are necessary)		
5-component brush	Order number	7685
Plastic PPN 0.5 for light to medium accumulations of dirt	Order number	7806
Plastics mix K 901 for light to medium accumulation of dirt on structured floors	Order number	7816
Plastic PPN 0.8 for light to heavy accumulations of dirt	Order number	7836
SIC PA 6 grain 180 gray for basic cleaning and very heavy accumulation of dirt	Order number	7843
SIC PA 6.12 grain 120 green for basic cleaning and extreme accumulation of dirt	Order number	7845
SIC PA 6 grain 600 gray (1 piece)	Order number	7826
Superpads (total of 3 are necessary)		
Drive plate (pad holder) with centerlock	Order number	7857
Pads, red for routine cleaning (5 pieces in box)	Order number	7838.05
Pads, brown for routine cleaning (5 pieces in box)	Order number	7837.05
Pads, black for basic cleaning and heavy accumulations of dirt (5 pieces in box)	Order number	7840.05
Microfiber pad	Order number	7850.02

Technical Data

Special equipment:		
Additional scrubbing and vacuuming tools (spraying-vacuuming tool)		
Floor scrubbing and vacuuming tool	Order number	7009
Vacuuming and spraying hose (length: 5 m)	Order number	7766
Tool holder and attachment part	Order number	7311.10
Additional tools for using the suction hose (hand-held vacuum cleaner)		
Adapter to connect the following tools	Order number	7893
Suction hose (length: 3 m)	Order number	7880
Suction pipe (length: 1.3 m)	Order number	7881
Suction nozzle with rubber lips	Order number	7883
Chemical dosing system	Order number	7678.70

5 Maintenance and Service

General information



It is essential to pay attention to the information in Chapter "Safety Information" before completing any service or maintenance work!

By adhering to the maintenance work recommended by us, you can be sure that the vehicle is always ready to be put into operation.

Maintenance and repair work necessary on a daily and weekly basis can be carried out by a driver trained to complete the work, all other Hako system maintenance may only be completed by personnel who are correspondingly qualified and trained. In case of doubt, please contact your nearest Hako service center or authorized Hako dealer. Failure to observe this annuls any rights to claims under the terms of guarantee in respect of resulting damage or consequential damage.

Always specify the serial number, indicated on the rating plate, when making any inquiries and orders for spare parts,

refer to Section 1.7.

5.1 Hako system maintenance

Hako system maintenance:

- ensures the Hako working vehicle is always ready for operation (preventive maintenance),
- minimizes operating costs, maintenance and repair costs,
- ensures the vehicle has a long service life.

The Hako system maintenance describes the specific technical work necessary for the individual modules and defines the intervals for the maintenance tasks. Individual parts which must be changed during maintenance tasks are defined and stipulated in spare parts kits.

Hako system maintenance, customer:

Work to be carried out by the customer according to the service and maintenance instructions in the operating manual (daily and weekly). Operating personnel are given the necessary instruction by specialists when the vehicle is delivered.

Hako system maintenance I:

(Every 250 operating hours)

Must be completed by a skilled technician in an authorized Hako service center according to the vehicle-specific system maintenance with a spare parts kit.

Hako system maintenance II:

(Every 500 operating hours)

Must be completed by a skilled technician in an authorized Hako service center according to the vehicle-specific system maintenance with a spare parts kit.

Hako system maintenance III/S:

(Every 1000 operating hours

Safety check)

Must be completed by a skilled technician in an authorized Hako service center according to the vehicle-specific system maintenance with a spare parts kit. Completion of all legally prescribed safety-related tests in Germany in accordance with UVV-BGV-TÜV-VDE.

Maintenance and Service

5.2 Maintenance report

<p style="text-align: center;">Handover</p> <p>Upgrading Test drive Handover to customer Instruction completed on:</p> <p>at _____ operating hours</p>	<p style="text-align: center;">Hako System Maintenance I 250 operating hours Workshop Stamp</p> <p>completed on:</p> <p>at _____ operating hours</p>	<p style="text-align: center;">Hako System Maintenance II 500 operating hours Workshop Stamp</p> <p>completed on:</p> <p>at _____ operating hours</p>	<p style="text-align: center;">Hako System Maintenance I 750 operating hours Workshop Stamp</p> <p>completed on:</p> <p>at _____ operating hours</p>
<p style="text-align: center;">Hako System Maintenance III/S 1000 operating hours Workshop Stamp</p> <p>completed on:</p> <p>at _____ operating hours</p>	<p style="text-align: center;">Hako System Maintenance I 1250 operating hours Workshop Stamp</p> <p>completed on:</p> <p>at _____ operating hours</p>	<p style="text-align: center;">Hako System Maintenance II 1500 operating hours Workshop Stamp</p> <p>completed on:</p> <p>at _____ operating hours</p>	<p style="text-align: center;">Hako System Maintenance I 1750 operating hours Workshop Stamp</p> <p>completed on:</p> <p>at _____ operating hours</p>
<p style="text-align: center;">Hako System Maintenance III/S 2000 operating hours Workshop Stamp</p> <p>completed on:</p> <p>at _____ operating hours</p>	<p style="text-align: center;">Hako System Maintenance I 2250 operating hours Workshop Stamp</p> <p>completed on:</p> <p>at _____ operating hours</p>	<p style="text-align: center;">Hako System Maintenance II 2500 operating hours Workshop Stamp</p> <p>completed on:</p> <p>at _____ operating hours</p>	<p style="text-align: center;">Hako System Maintenance I 2750 operating hours Workshop Stamp</p> <p>completed on:</p> <p>at _____ operating hours</p>

Maintenance and Service

5.3 Maintenance schedule

The following maintenance work must be completed by the customer at the intervals stipulated. It relates to the daily and weekly maintenance work.

5.3.1 Hako system maintenance, customer

Activity	Interval
	Daily
<u>Directly prior to starting operation:</u>	
Fill the solution tank (dose the cleaning agent, fill fresh water)	o
<u>Before or after operation:</u>	o
Check the properties of the deflectors to the right and left and repair them or replace the deflector rubber (left and right) as necessary	o
Check the service brake in terms of its functionality and for signs of leaks; repair as necessary	o
Check the parking brake in terms of its functionality and for signs of leaks; repair as necessary	o
Check the squeegee is clean and undamaged	o

Maintenance and Service

Activity	Interval
	Daily
<u>After the end of operation:</u>	o
Empty the recovery tank	o
Clean the recovery tank	o
Clean the air intake filter (waste water filter)	o
Clean the fresh water filter	o
Check the battery charge; recharge as necessary	o

Maintenance and Service



Before completing the weekly maintenance work described below,

subject all the operating elements to a function test in order to check whether the vehicle is ready for operation.

Activity	Interval
	Weekly
Check the acid level of the battery and refill distilled water as necessary	o
Check the electrical system (including working lights) and repair as necessary	o
Brush head: Check the deflectors on the right and left and complete any repairs or order spare parts and replace them as necessary	o
Check the squeegee, particularly the rear sealing strip, is clean and for signs of damage and wear and complete any repairs or order spare parts and replace them as necessary	o
Check the recovery tank through the inspection hole at the top for signs of premature wear (due to glass splinters, metal chips, grit, etc.) or damage and clean it	o
Check the vehicle is clean; clean it, if necessary	o
Complete a test drive and function test (including brake tests)	o

Maintenance and Service

5.3.2 Hako system maintenance I

The following maintenance work must be completed by an authorized Hako service center.

Activity	Interval
	Every 250 operating hours
Check the battery in terms of acid level, acid density and voltage per cell; clear up any defects as necessary	o
Change the gear oil in the hydraulic motor	o
Grease the rotary joint	o
Check the service brake for leaks, check the main brake cylinder and actuating rods, clear any defects	o
Check the brake fluid in the service brake; refill and bleed as necessary	o
Subject the service brake to a brake tests; clear any defects as necessary	o
Check the parking brake for actuating play; repair as necessary	o
Subject the safety catch to a function test (to release the parking brake)	o
Check the steering for steering play and adjust as necessary	o
Lubricate and grease the steering	o

Maintenance and Service

Activity	Interval
	Every 250 operating hours
Check the torque of the rear wheel nuts; adjust as necessary	o
Check the scrubbing unit and service as necessary: brushes, water retaining ring, brush catches, parallel alignment of holding attachment	o
Check the deflectors on the scrubbing unit and replace them as necessary (left and right)	o
Grease the scrubbing unit joints and connecting rods	o
Check the recovery tank, particularly the lid sealing quality and filter sieve	o
Change the O-rings in the draining hose and dosing valves	o
Check the suction hose is fitted properly and for signs of damage; clear any defects as necessary	o
Test the squeegee functions: pivot, raise/lower, deflecting rollers	o
Check front and rear sealing strips of the squeegee; change as necessary	o

Maintenance and Service

Activity	Interval
	Every 250 operating hours
Check the knurled nuts on the squeegee; change as necessary	o
Grease the joints and connection rods of the waste water vacuuming system	o
Adjust the support wheels on the squeegee	o
Check the vacuum at the suction hose; clear any defects	o
Check the electrical safety functions: parking brake, recovery tank float switch	o
Check the vehicle's condition visually: color, corrosion and presence of all signs and labels	o
Check the vehicle is clean; clean it, if necessary	o
Test drive and test all function and safety-relevant component including brake tests	o
Complete a test report in accordance with the German UVV and BGV and German TÜV and VDE requirements	o
Inspection label	o
Logbook	o
On request against separate account: driver training	o

Maintenance and Service

5.3.3 Hako system maintenance II

The following maintenance work must be completed by an authorized Hako service center.

Activity	Interval
	Every 500 operating hours
Complete all activities in Hako system maintenance I, refer to Section 5.3.2	o
In addition:	
Check the output of the hydraulic motor (forwards, reverse); clear defects as necessary	o
Check the carbon brushes of the hydraulic motor ; replace, if necessary	o
Check the brush motor output (left and right); clear defects as necessary	o
Check the carbon brushes of the brush motors; replace, if necessary	o
Including visual inspection, test drive, test report, inspection label and logbook refer to Section 5.3.2	o

Maintenance and Service

5.3.4 Hako system maintenance III/S (safety check)

The following maintenance work must be completed by an authorized Hako service center at least once a year.

Activity	Interval
	Every 1000 operating hours
Complete all activities in Hako system maintenance I and II, refer to Section 5.3.2 and Section 5.3.3	o
In addition:	o
Check the brake linings on the rear wheels; change as necessary	o
Change the brake fluid in the service brake	o
Including visual inspection, test drive, test report, inspection label and logbook refer to Section 5.3.2	o

Maintenance and Service

5.4 Battery system

The scrubber drier is operated by means of a low-maintenance trough battery, refer to Sections 3.1.8 and 4. The battery is comprised of 18 individual cells connected in series.

- 1 Battery and charge control indicator (including TSG indicator) in left operating panel
- 2 Battery connection cable
- 3 Battery plug in vehicle socket
- 4 Battery plug (disconnected)
- 5 Seat console, open
- 6 Fill level indicator for battery acid and distilled water
- 7 Aquamatic plug
- 8 Battery interconnection cable
- 9 Insulation cap
- 10 Fitting hole in battery trough
- 11 Battery cell (individual battery)
- 12 Wiring diagram

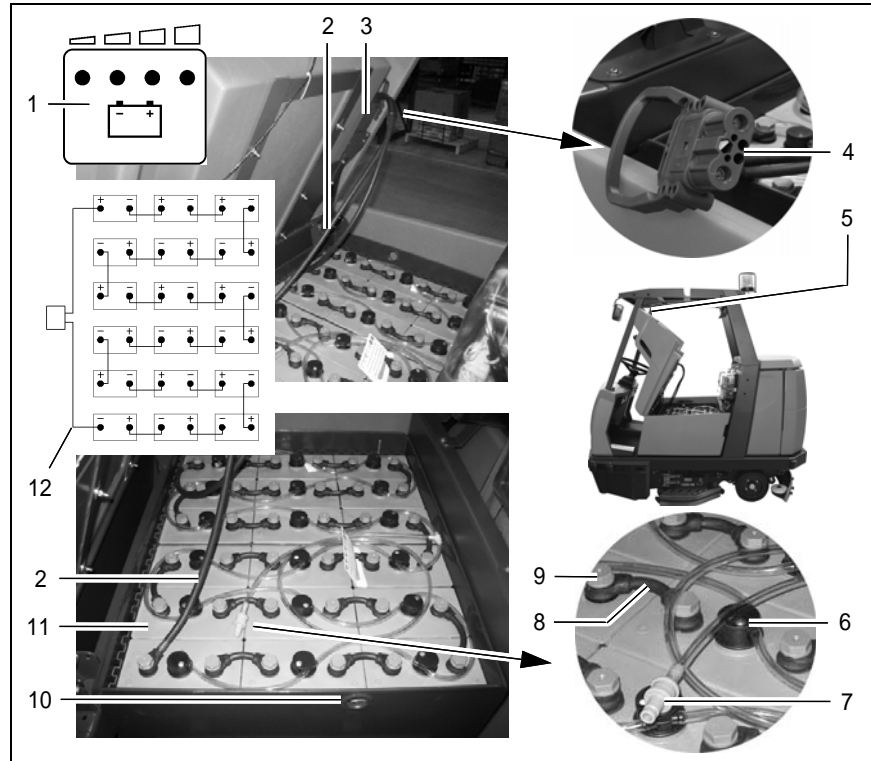

Fig. 25

Maintenance and Service

General information on handling batteries



Pay attention to the safety information in Section 1.4 and Section 1.5.2 as well as the information on servicing and maintenance in the battery documents.



Also refer to the information in the supplementary sheet 88-60-2556 "Information on driving batteries".

- Always disconnect the battery plug before starting any work on the electrical installation.
- Batteries may only be handled and changed by properly skilled maintenance personnel.
- Pay attention to legal requirements and local directives.

5.4.1 Charging batteries



Before starting the vehicle up for the first time, the batteries to be used must be properly charged by implementing the initial battery charge routine, refer to Section 2.2. Hako assumes no liability for damage to the battery caused by a fault when the battery is charged for the first time.



There must be sufficient ventilation in the charging area - risk of explosion!



The seat console (Fig. 25/5) must be open during the battery charging process to prevent the development of explosive oxyhydrogen!



Only use the original charger! Pay attention that the insulation is not initially damaged and not damaged during the charging process. The cable must not rub against anything. Do not use the charger if the insulation is damaged.

We recommend charging the battery when at least one dot of the battery indicator has gone out after operating the machine. The indicator (Fig. 25/1) also indicates the charge status of the batteries during the charging process.

- Connect the battery plug (Fig. 25/4) to the battery charger supplied.
- Pay attention to the information in the operating manual supplied with the charger and the manual from battery manufacturer.



Do not inhale battery gases.

Maintenance and Service

5.4.2 Servicing the driving batteries

Checking the acid level

The battery acid level must be checked by the customer on a weekly basis and distilled water must be topped up, if necessary; also refer to Sections 5.3.1 and 5.3.2.



There must be no naked flames used in the vicinity when handling batteries, particularly when checking the acid level.

The battery cells are provided with fill level indicators (Fig. 25/6) which ensure the correct height of electrolyte is maintained: The white point must be clearly visible at the top. If this is not the case, distilled water must be refilled.

Topping up the battery is completed via the connection coupling, the aquamatic plug (Fig. 25/7), which is then connected to the water filling device. This is not part of the scope of delivery.

Details on the filling process are contained in the manual provided with the water filling device.



Spilled battery acid must never enter the sewage system in its initial form, it must be neutralized beforehand: e.g. diluted with plenty of water or absorbed with granulate.

Checking the acid density and voltage of each cell

These points must be checked and corrected at regular intervals within the scope of Hako system maintenance by an authorized service center.



Also refer to the information in the supplementary sheet 88-60-2556 "Information on driving batteries".

5.4.3 Disassembling the trough battery

1. Park the vehicle on a level area of floor.



Turn the key switch to position 0 and remove the key.

2. Open the side doors to the left and right (Fig. 26/3).
3. Positioned on the right-hand side of the vehicle, take hold of the seat console at the handle (Fig. 26/2) and pivot up towards the front.



Pivot the seat console (Fig. 26/1) open from the right-hand side of the vehicle otherwise your hands could be crushed between the seat console and cab safety roof (if fitted).

4. Disconnect the battery and vehicle plug (Fig. 26/5+6).



When disassembling the trough battery, use appropriate lifting gear.

Maintenance and Service



The battery may only be disassembled using lifting gear by properly trained personnel.



If the scrubber drier is equipped with a cab safety roof, lift the trough battery out on the left-hand side of the battery. The cab safety roof has a recess (Fig. 26/4) for the lifting gear rope.

5. Guide the lifting gear from the left to the battery and hang the hooks in the fitting holes on the battery trough (Fig. 26/7).
6. Lift the battery trough out of the vehicle using the lifting gear.

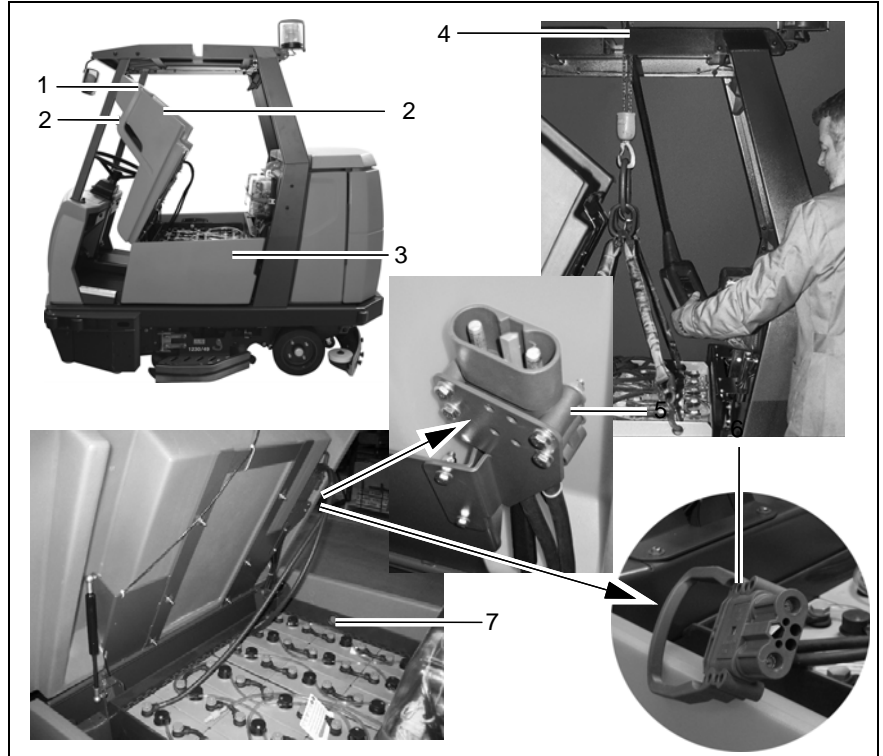

Fig. 26

Maintenance and Service

5.4.4 Installing the trough battery



Set the key switch to position 0 (refer to paragraph “Key switch” in Section 3.2.3) and remove the key.

1. Open the side doors to the left and right (Fig. 26/3).
2. Take hold of the seat console (Fig. 26/1) at the handle (Fig. 26/2) and pivot it forwards to open it.



If a cab safety roof is fitted, open the seat console from the right-hand side of the vehicle otherwise your hands could be crushed between the seat console and cab safety roof.

Install the trough battery in the vehicle from the left-hand side of the vehicle using lifting gear or a fork-lift truck according to the figure 26.



If the scrubber drier is fitted with a cab safety roof, the trough battery can only be installed from the left-hand side of the vehicle; the cab safety roof is provided with a recess (Fig. 26/4) for the lifting gear rope.



When installing the trough battery, use appropriate lifting gear.



The battery may only be installed using lifting gear by properly trained personnel.

Connect the battery plug (Fig. 26/6) and vehicle socket (Fig. 26/5) to each other. Ensure they are connected firmly.

5.4.5 Disposing of batteries

Used batteries with the recycling symbol contain reusable commodities. The heavy metals contained represent a major risk both to people's health and to the environment. Never open or damage batteries. Never touch, inhale or swallow the content of batteries. Health hazard! Do not allow batteries to get into the environment. Risk of contaminating the ground and water!

In accordance with symbol with the crossed out garbage bin, these batteries must not be disposed of in domestic waste. Return and recycling of old batteries must be agreed on with Hako's authorized dealers in accordance with § 6 and § 8 German Battery Law (BattG).

5.4.6 Total discharge signal transducer (TSG)

The scrubber drier is equipped with a charge control for protection against total discharge of the batteries. The total discharge signal transducer (TSG) is integrated in the electronic system and setup at the factory for battery type PzS (armor plate insulation) (digit in the service indicator: No. 5). If other batteries are used, the total discharge signal transducer must be adjusted.



The total discharge signal transducer may only be adjusted by an authorized Hako service center.

Also refer to Section 3.1.8.

5.5 Solution tank

- 1 Lid seal
- 2 Cap
- 3 Opening to recovery tank (airing and venting)
- 4 Solution tank
- 5 Solution filter
- 6 Ball cock
- 7 Screw cap
- 8 Solution draining hose

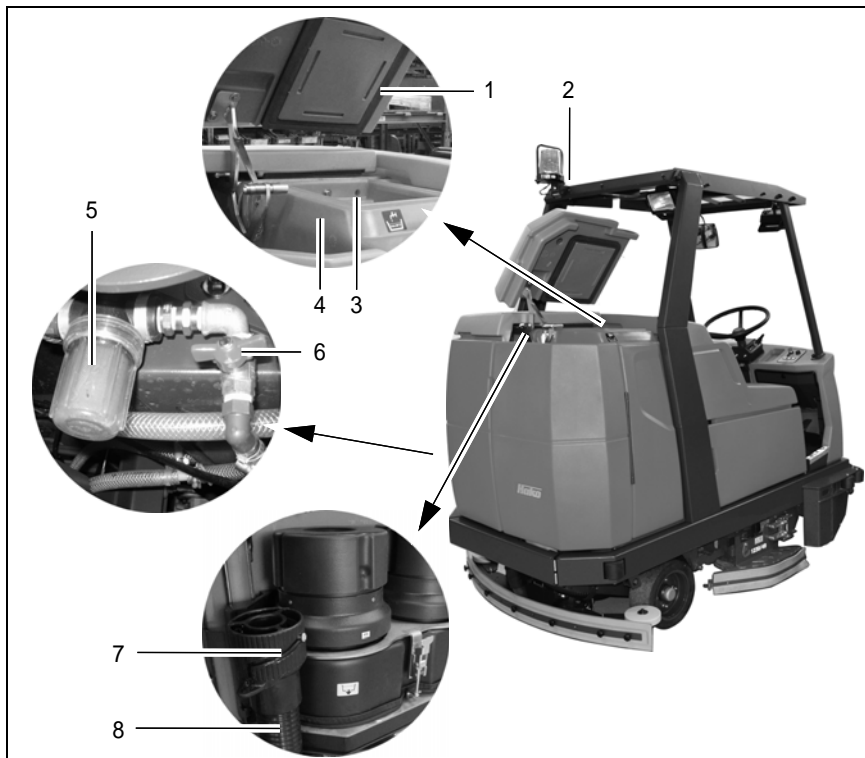

Fig. 27

Maintenance and Service

5.5.1 Filling the solution tank

Fill the solution tank (Fig. 27/4) with fresh water and cleaning agent before starting with the work, also refer to Section 3.1.4.

1. Park the machine on a level floor area.
2. Open the tank cap (Fig. 27/2) and lock in place.
3. Fill the solution tank to the maximum mark.

5.5.2 Emptying the solution tank

If the vehicle is to be left unused for a longer period, the solution tank (Fig. 27/4) should be emptied.

1. Park the vehicle so that the solution draining hose (Fig. 27/8) can be positioned over a drain in the floor.
2. Open the left and right rear doors.

3. Detach the solution draining hose (Fig. 27/8) and lower it slowly.
4. Unscrew the screw cap (Fig. 27/7). The quantity drained can be regulated by turning the screw cap and pivoting the cap open fully, if necessary.
5. When the solution tank has been completely emptied, screw the cap shut again and attach the draining hose again.
6. Close the left and right rear doors.



When disposing of the waste water containing the cleaning agent, observe all applicable legal regulations.

5.5.3 Cleaning the draining hose cap

- The screw cap (Fig. 27/7) at the end of the draining hose (Fig. 27/8) should be cleaned at regular intervals.
- Lubricate the O-ring lightly, if necessary.

5.5.4 Cleaning the solution filter

The solution feed is equipped with a filter (Fig. 27/5) which must be cleaned if dirt appears on the container. This is located on the left-hand side of the vehicle at the height of the brushes behind the side panel.

1. Pivot the right-hand side panel up.
2. Close the ball cock (Fig. 27/6) to prevent solution being supplied from the tank.
3. Unscrew the container by hand and pull the sieve insert out downwards.
4. Clean both parts with water and reassemble them.

5.6 Recovery tank

- 1 Ca
- 2 Lid seal
- 3 Recovery tank
- 4 Air intake filter
- 5 Screw cap
- 6 Waste water draining hose
- 7 Cleaning flap

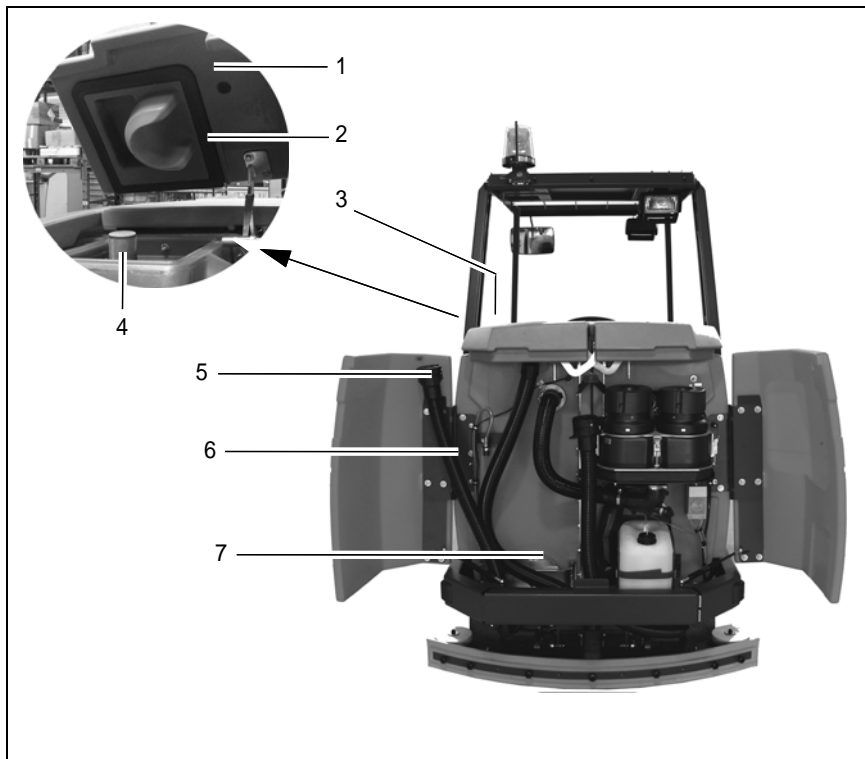

Fig. 28

Maintenance and Service

5.6.1 Emptying the recovery tank



The recovery tank (Fig. 28/3) must be emptied and flushed clean after finishing work.



Observe the applicable laws and local regulations when disposing of waste water containing cleaning agents!

1. Park the vehicle so that the waste water draining hose (Fig. 28/6) can be positioned over a drain in the floor.
2. Open the left and right rear doors.
3. Detach the waste water draining hose (Fig. 28/6) and lower it slowly.

4. Unscrew the screw cap (Fig. 28/5). The quantity drained can be regulated by turning the cap and pivoting the cap open fully, if necessary.
5. When the recovery tank has been completely emptied, screw the cap shut again and attach the draining hose again.



If the recovery tank is extremely dirty, begin cleaning the tank straight away.

6. Close the left and right rear doors.

5.6.2 Cleaning the recovery tank

Clean the recovery tank (Fig. 28/3) every day or as necessary. The cleaning flap (Fig. 28/7) is available for this.



The cleaning flap must not be used to drain off waste water.

1. Open the left and right rear doors.
2. Empty the recovery tank, refer to Section 5.6.1.

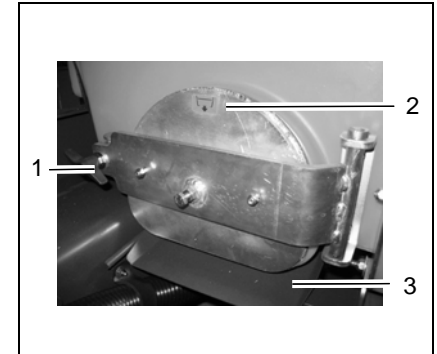

Fig. 29

3. Pull out the run-off plate (Fig. 29/3).
4. Release the flap lock: turn the wing nuts (Fig. 29/1) counterclockwise.

Maintenance and Service

5. Open the cleaning flap (Fig. 29/2). In the recovery tank a tube (Fig. 30/1) is located. This tube serves to support the membrane wall.



The tube must not be used to clean the recovery tank! Ignoring of this notice the membrane wall can be damaged.

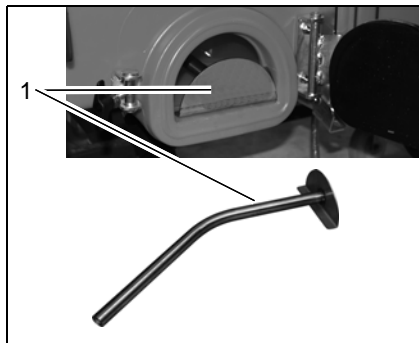

Fig. 30

6. Remove the tube from the recovery tank.
7. Open the recovery tank cap (Fig. 28/1).
8. Flush the recovery tank with water filled from the top through the open tank cap.



Cleaning may only be carried out using a water hose (operating pressure approx. 5 to 6 bar) and only from top to bottom. Do not aim the jet of water directly at openings, slits, electronic components, operating panels or seals.



It is not permitted to clean the vehicle with a high-pressure washer or with a steam blaster because the temperature is in excess of 212 °F.



Wear appropriate gloves for protection against dirt, viruses, bacteria etc. when cleaning the container.

9. After finishing cleaning the tank, place the tube into the recovery tank, close the flap and push the run-off plate back in place.
10. Unhook the waste water draining hose (Fig. 28/6), lower it slowly and open the cap (Fig. 28/5).
11. Run fresh water in the recovery tank through the open cap using a water hose (output pressure approx. 5 to 6 bar) and, in doing so, also flushing the draining hose (see above).
12. Screw the cap shut again and hook the draining hose back in place.
13. Close the left and right rear doors.

Maintenance and Service

5.6.3 Cleaning the draining hose cap

- Clean the screw cap on the waste water draining hose (Fig. 28/6) daily.
- Lubricate the O-ring lightly, if necessary.

5.6.4 Cleaning the air intake filter

The filter sieve (Fig. 31/1) is located in the recovery tank above the maximum water level on the suction pipe. The accumulation of dirt in the filter sieve must be checked daily and cleaned as necessary:

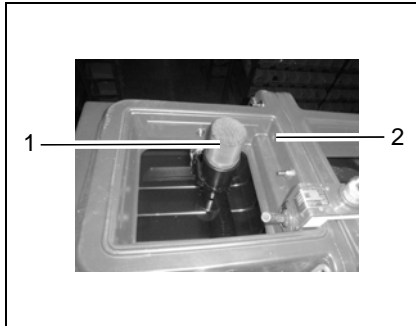

Fig. 31

1. Pull the filter sieve from the suction pipe and clean with water.



Remove the filter sieve completely to clean it.



During cleaning and operation, pay attention that no water and no particles of dirt get into the suction pipe and into the suction turbines.

2. Dry the filter sieve after cleaning. Do not replace when dripping wet!

5.6.5 Cleaning the openings to the solution tank

The openings between the recovery and solution tank (Fig. 31/2) serve for ventilation between the two tanks. They must be checked regularly for accumulations of dirt and cleaned as necessary.

5.7 Scrubbing unit



The scrubbing unit (Fig. 32/1) may only be disassembled and assembled by properly trained service personnel.

The brushes, part of the scrubbing unit, are not contained in the scope of delivery. Select the brushes according to your needs and install them on the brush head (Fig. 32/2) according to the instructions, refer to Section 2.3.1.

5.7.1 Changing the brushes

- Check the brushes on the brush head weekly for signs of wear.
- When the brushes have worn to a bristle length of 1.5 cm, the brushes must be replaced, refer to Section 2.3.1.



Before working on the brushes, switch off the scrubbing unit, turn the key switch to position 0 and remove the key.



Fig. 32

5.7.2 Installing new rubber deflector strips

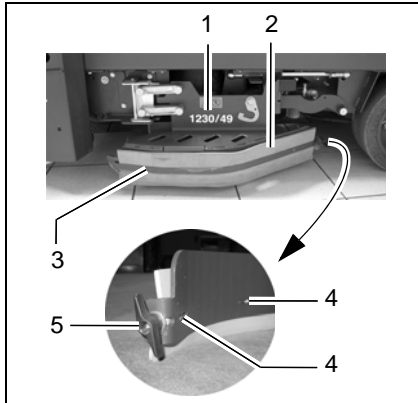

Fig. 33

- 1 Deflector
- 2 Rubber deflector strips
- 3 Clamping rail
- 4 Clamping rail hooks
- 5 Wing nuts



The deflector (Fig. 33/1) must be fixed in its service position (refer to Section 2.3.1, Point 3).

1. Loosen the wing nut (Fig. 33/5) at the end of the deflector.
2. Slide the clamping rail (Fig. 33/3) in the vehicle's driving direction (forwards) until the clamping rail hooks (Fig. 33/4) are freed and the clamping rail (Fig. 33/3) can be removed away from the vehicle.
3. Remove the old rubber deflector strips (Fig. 33/2).

4. Position the new rubber deflector strips (Fig. 33/2) in place.
 5. Mount the clamping rail (Fig. 33/3) from the outside and slide back by hand so that the clamping rail hooks (Fig. 33/4) engage.
- Tighten the wing nut (Fig. 33/5) so that it engage in the thread of the clamping rail (Fig. 33/3) and tightens the clamping rail firmly (Fig. 33/3).

5.8 Squeegee

- 1 Squeegee holding attachment
- 2 Wing nuts
- 3 Connection nozzle
- 4 Sealing strip (rear)
- 5 Support strip (rear)
- 6 Clamping rail (rear)
- 7 Support roller
- 8 Knurled nut

The squeegee is also equipped with front sealing and support strips and clamping rail (Fig. 35).

5.8.1 Cleaning the squeegee

Inspect the squeegee when raised daily and clean as necessary.

5.8.2 Disassembling the squeegee

1. Insert the key in the key switch and turn the key switch on.
2. Lower the squeegee: Press the button for the squeegee and suction turbine so that the green control lamp lights up.

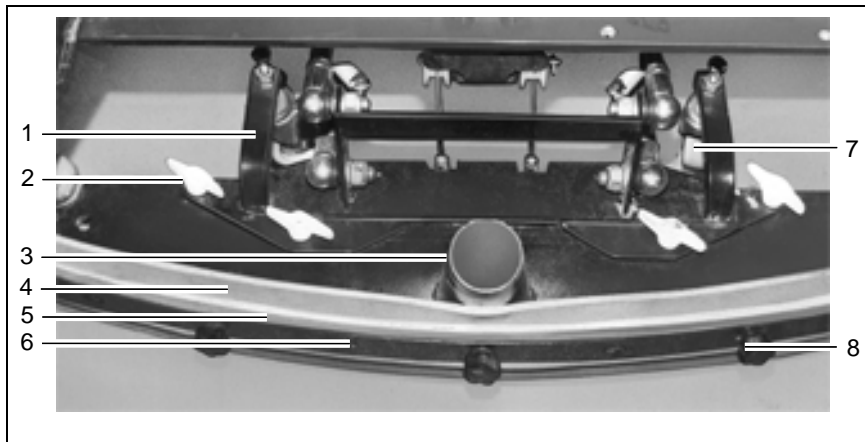

Fig. 34

3. Switch off the key switch and remove the key.
4. Open the rear doors.
5. Pull the suction hose from the connection nozzle (Fig. 34/3) of the squeegee.
6. Loosen the wing nuts (Fig. 34/2) on the holding attachment.

7. Pull the squeegee away to the rear under the holding attachment.
8. Insert the key in the key switch and turn the key switch on.
9. The squeegee is lifted automatically.
10. Close the rear doors.

Maintenance and Service

5.8.3 Installing the squeegee

Refer to Section 2.3.2.

5.8.4 Changing the sealing strips

The sealing strips (Fig. 34/4) can be changed without the need for any tools:

1. Disassemble the squeegee, refer to Section 5.8.2
2. Unscrew the knurled nuts (Fig. 34/8).
3. Remove the sealing strip, support strip and clamping rail (Fig. 34/4-6).



Both sides of the sealing strip can be used.

4. Install the new or reversed sealing strips in the reverse working sequence.



Pay attention that both sealing strips (front and rear) touch the floor when mounted.

5. Tighten the knurled nuts evenly, starting from the center and working on alternate sides.



There must be no bends in the sealing strip.

6. Disassemble the front sealing strip (Fig. 35) in the same way.

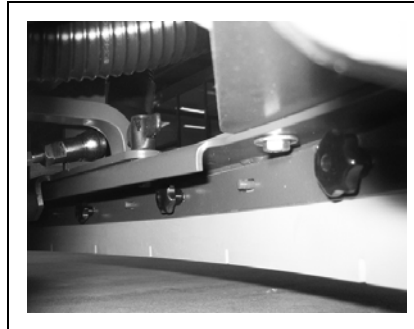

Fig. 35

7. After changing the sealing strips, check that the squeegee stands vertically on the floor. Otherwise, readjust the support rollers.



When the vehicle is in operation, the sealing strips must be bent a little to the rear when the squeegee is lowered.

5.8.5 Adjusting the support rollers

The squeegee stands with the sealing strips (Fig. 34/4) and support rollers (Fig. 34/7) on the ground. To increase the squeegee contact surface of the sealing strips (Fig. 34/4) on the floor, e.g. following wear of the sealing strips (Fig. 34/4), the support rollers (Fig. 34/7) must be set higher:

1. Position the squeegee on a level, solid surface.
2. Loosen the counter nuts in each support roller.
3. Adjust the support rollers (Fig. 34/7) on the right and left evenly:
 - Turn the screw counterclockwise to raise the support roller.
 - Turn the screw clockwise to lower the support roller.
4. Check the squeegee contact surface and adjust, if necessary.
5. Tighten the counter nuts on each support roller (Fig. 34/7).

Maintenance and Service

5.9 Wheels

5.9.1 Front wheel

In the case of problems with the front wheel, please contact an authorized Hako service center.



The front wheel may only be changed at an authorized Hako service center.

5.9.2 Rear wheels

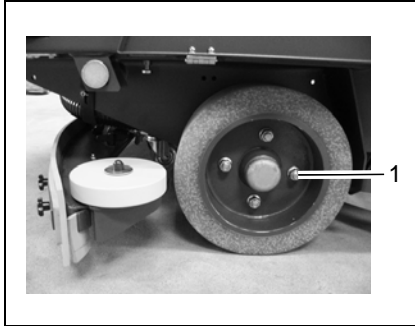

Fig. 36

- The wheel nuts on the rear wheels (Fig. 36/1) must be subjected to their first check after 100 operating hours and subsequently every 200 hours.



The tightening torque for the wheel nuts (Fig. 36/1) is 140 Nm.

Changing the rear wheels

- To change the rear wheels, the scrubber drier must be jacked up on the right or left side.
- The contact points for the jack (lifting force: 2.0 t) are on the frame in front of the rear wheels.

Removing the rear wheels

- Remove the wheel nuts (Fig. 36/1).
- Remove the wheel.

Mounting the rear wheels

- Install the wheel in place.
- Screw on and tighten the wheel nuts (Fig. 36/1).

5.10 Electrical installation

5.10.1 Red control lamps

Refer to Section 3.2.2.

5.10.2 Error codes

Refer to Sections 3.5.1 and 3.2.2.

5.10.3 Fuses

The fuses are located in the electronic system underneath the seat console. Take hold of the seat console by the handle and pivot it up.



Always disconnect the battery plug before starting any work on the electrical installations.

All the lifting elements and brush motors in the scrubber drier are equipped with safety fuses and electronic fuses. Safety fuses are installed in:

- the suction turbines (35A high current fuse)
- the water pump and relief valve for the water supply (10A plug-in fuse)
- the hydraulic motor (160A current limiter in the drive control) and
- the working lights and flashing beacon, the key switch and horn (10 A plug-in fuse (F51)).



When these fuses blow, the vehicle is out of operation. This is not indicated by an alarm signal on the operating panel!

5.10.4 Drive control relay

The drive control is located in the left - hand part of the driver's cab underneath the foot plate.



Always disconnect the battery plug before starting any work on the electrical installations.

- Loosen the screws in the foot plate and remove the foot plate.
- Relay K3 (main contactor) is mounted upstream from the drive control.
- Replace a defect relay with a new one.
- Replace the foot plate and fix by means of the screws.

Maintenance and Service

5.11 Cleaning the vehicle

- Clean the vehicle on a weekly basis, refer to Section 5.3.1.
- Park the vehicle in an appropriate washing area.



Observe the applicable laws and local regulations when disposing of water containing cleaning agents and dirt!

- Switch the vehicle off and remove the key.
- The vehicle may only be cleaned using a water hose (operating pressure approx. 5 to 6 bar) and only from top to bottom.



It is not permitted to clean the vehicle with a pressure washer or steam blaster.

- Do not aim the jet of water directly at openings, slits, electronic components, operating panels or seals.

- It is not permitted to use aggressive and corrosive cleaning agents.
- Allow the vehicle to dry after cleaning. It is preferable to allow the vehicle to dry over a longer period of time, e.g. the weekend.

Maintenance and Service

5.12 Transporting and towing Loading



Observe the operating information on transportation!



Check the load bearing capacity of the loading platform prior to loading.

- Dead weight of the scrubber drier without battery, without options and without driver: 770 kg
- Total weight of the scrubber drier with battery and filled clean water tank, with cab safety roof and side scrubbing unit, without driver: 1670 kg
- When loading onto a truck or something similar by means of a loading ramp, the ramp angle must not exceed 15%.
- The squeegee and brush head must be raised.

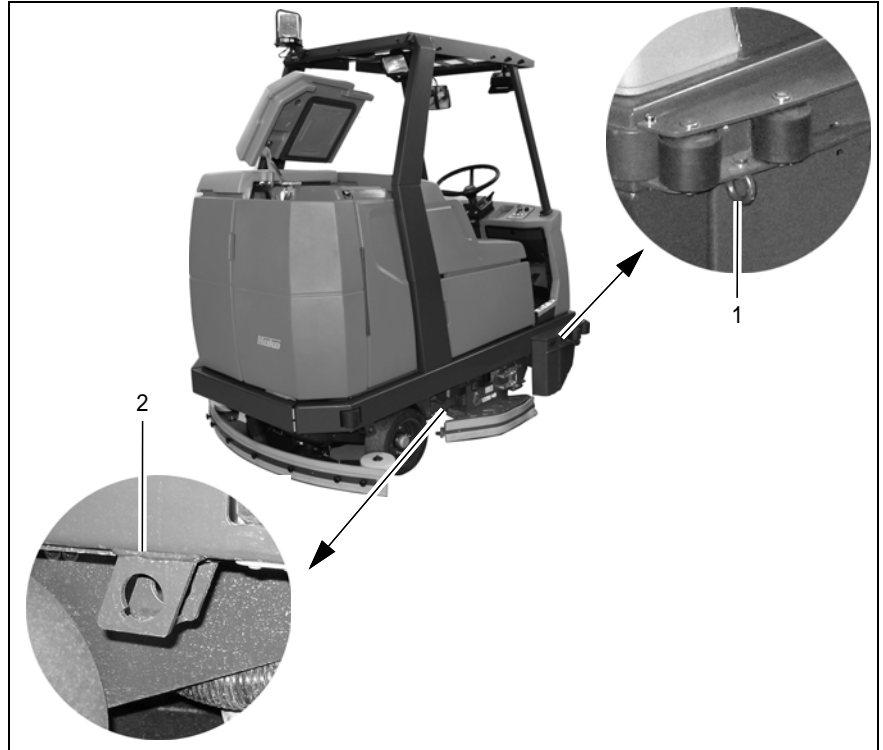

Fig. 37

Maintenance and Service

Transport

- When driving to the area of use, the squeegee and scrubbing unit must be raised.
- When the machine is to be transported on another vehicle or trailer, it must be secured against rolling away. Lash the machine down securely.
- The vehicle is provided with attachment points (lashing eyes) on the left and right-hand side to do this: at the rear of the frame and on the sides at the height of the entry area (Fig. 37/1+2).

Towing the vehicle

If it should become necessary to tow the scrubber drier, only do it on a level floor and at a maximum towing speed of 4 kph. The tow rope must be attached at the front lashing points.

EC Declaration of Conformity (in accordance with EC Directive 2006/42/EC)

Hako GmbH
Hamburger Straße 209-239
D-23843 Bad Oldesloe

declares that the products

Scrubmaster B310 R
Scrubmaster B310 R CL
Type: 7580

to which this declaration relates, conform to the relevant provisions of the safety and health requirements stipulated in EC Directive 2006/42/EU and is in accordance with 2004/108/EU.

Reference was made to the following standards and/or norms and/or technical specifications to ensure proper implementation of the safety and health requirements in the EU Directive:

DIN EN 60335-2-72
DIN EN 61000-6-2
DIN EN 55012

Bad Oldesloe, 26.09.2013



Dr. Rainer Bavendiek
Director R&D

Name of the authorized person who compiles technical documents for Hako:

Ludger Lüttel

Hako

Clean ahead

Advanced Technology for a Cleaner, Better Environment



Hako GmbH • Hamburger Straße 209-239 • D-23843 Bad Oldesloe
☎ +49 4531 806-0 • Fax +49 4531 806-338

88-10-3032 - 3100-08