



Instruction manual

Sweepmaster B1200 RH (6300.30)

Introduction

Preface

Dear customer, It is our desire that the good characteristics of the Sweepmaster B1200 RH should justify the confidence you demonstrated by making this purchase.

Prior to the first drive, carefully read the chapter "Safety Information" as well, in order to ensure you a safe working with the machine.

Your own safety, as well as the safety of others, depends to a great extent on how the vehicle is moved and operated. Therefore, carefully read and understand this operation and maintenance manual prior to the first drive.

The manual provides valuable information about operation, service and maintenance. The warning symbols as used in this manual identifies items relevant to safety. Please observe the safety provisions (see chapter "Safety Information").

Your authorised Hako dealer will be pleased to answer further questions regarding the vehicle or the operation and maintenance manual.

Please be advised explicitly that we cannot accept any legal issues out of the contents of this manual. If repair work has to be performed make sure that only genuine spare parts are used; only genuine spare parts may guarantee a dependable machine. We reserve the right for technical improvement.

Valid as of: April 2014

Hako GmbH
D-23843 Bad Oldesloe
Hamburger Str. 209-239
Telephon ++49 (04531) 8060

Proper use

The Sweepmaster B1200 RH is a sweeper intended for commercial use and has been exclusively designed for collecting dry and moist matter from floor surfaces in e.g. factories, storage buildings, parking grounds and pedestrian areas. Using the machine beyond this scope of application will be deemed improper use; The manufacturer cannot be held liable for consequential damag-

es; the user alone bears the risk. The Sweeper is not suitable for collecting toxic, combustible or other matters which are hazardous to health. The term of proper use also includes operation, maintenance and repair work to be performed in compliance with the manufacturer's specifications. The Sweepmaster B1200 RH may only be used by persons that are familiar with the machine and aware of possible hazards involved. The applicable Accident Prevention Regulations and further regulations in vigour concerning aspects of safety and working medicine will have to be complied with.

Based on the conception, design and construction of the model introduced onto the market by us, the machine complies with the applicable basic safety and health requirements stipulated in the EC Directive (refer to Declaration of Conformity). This declaration is no longer considered valid in the event of modifications to the machine not authorized by us. The manufacturer is not deemed liable for any damage resulting from unauthorized modifications to the machine.

Introduction

Notes on warranty

The terms of the sales contract apply. Damages are not subject to warranty if they are due to non-compliance with the maintenance and service provisions. The maintenance work has to be performed by an authorized Hako service center and confirmed in the "Maintenance certificate" which is the warranty document.

The following is excluded from warranty: fuses, natural wear, damages caused by overload, inexpert handling and unauthorized modification of the machine. Moreover, any claim for warranty cannot be accepted if damages of the machine are caused by fitting parts or accessories without Hako's prior and explicit consent or by non-compliance with the maintenance instructions.

Acceptance of the machine

Upon arrival, check machine for possible damages in transit. Follow unpacking instructions on shipping pallet. Each unit has been tested and thoroughly inspected before shipment. Any damage is the responsibility of the delivery carrier who should be notified immediately.

Disposing of the machine

Render the machine inoperable. It must not represent a source of risks to children. Dispose of the machine in accordance with the applicable local regulations. For further information on disposal and recycling, contact the authorized Hako dealer where you purchased the machine.



Used batteries with the recycling symbol contain reusable commodities. The heavy metals contained simultaneously represent a serious risk to health and to the environment. Never open batteries or damage them. Never touch, inhale or swallow any material inside batteries. Health hazard! Never allow batteries to pollute the environment. Risk of contaminating the ground and water! In accordance with the symbol with the crossed out bin, these batteries must not be disposed of in domestic waste. The return and recycling of old batteries must be agreed on with your authorized Hako dealer in accordance with the Battery Law § 6 and § 8 (BattG).

Regulations for Approval

According to §18 of the German Motor Vehicle Construction and Use Regulations (StVZO), the Sweepmaster B1200 RH is an automotive machine. The manufacturer supplies the expertise required for type approval. On the base of this expertise, the local approval authority submits the valid type approval. Unnecessary is a registration number. According to §29 of the German Motor Vehicle Construction and Use Regulations (StVZO) is a general inspection unnecessary too, as the type definite maximum speed is minor 20km/h. According to the German Motor Vehicle Construction and Use Regulations (StVZO), the machine has to be equipped with first aid kit, warning triangle and the type approval certificate when being used on public roads, paths and places.

Any modification carried out at the Sweepmaster B1200 RH and having an influence on the type approval specifications and are not indicated there will render the type approval invalid. Before receiving a new type approval, the machine has to be presented to an authorized expert for issue of new expertise.

Introduction

This expertise turns type approval after being stamped by approval authority.

Driving Licence

According to the Driving Licence Act, any person who is driving a vehicle running at a construction-defined maximum speed of 6 km/h or more on, public roads, paths and places has to hold a valid driving licence. A driving licence of the class L is required for driving the Sweepmaster B1200 RH (automotive machine up to a speed of 25km/h).

Introduction

Table of Content



Introduction	2	3	Operation	20	5.4.5 Plug Connection Coding . . .	46
Preface	2	3.1 Working Procedure	20	5.4.6 Batterie einsetzen	48	
Proper use	2	3.1.1 Sweeper Roller	21	5.5 Sweeper Unit	50	
Notes on warranty	3	3.1.2 Side Broom	21	5.5.1 Mount/Dismount Sweeper Roller	50	
Acceptance of the machine . . .	3	3.1.3 Steering	21	5.5.2 Adjust Sweeping Track	51	
Disposing of the machine	3	3.1.4 Filter System Dust Evacuation	22	5.5.3 Sealing Strips for Broom Compartment	52	
Regulations for Approval	3	3.1.5 Shaking System	22	5.5.4 Replace Side Broom	52	
Driving Licence	4	3.1.6 Brake	23	5.5.5 Dismount Plate Filter	53	
1 Safety information	7	3.1.7 Travel Drive Assembly	23	5.5.6 Basic Cleaning of Plate Filter	54	
1.1 Safety and Warning Symbols .	7	3.1.8 Hydraulic System	23	5.6 Hydraulic System	55	
1.2 General Provisions	8	3.2 Operating Elements	24	5.6.1 Check Hydraulic Fluid Level	55	
1.3 Provisions for Operation	8	3.2.1 Control Panel Sweepmaster B1200 RH	26	5.6.2 Refill Hydraulic Fluid	56	
1.4 Maintenance instructions	9	3.2.2 Emptying of the Dirt Hopper . .	30	5.6.3 Change Hydraulic Filter	56	
1.5 Specific Hazards	11	4 Technical Data	32	5.6.4 Change Hydraulic Fluid	57	
1.6 Information for Protection of En- vironment	12	5 Maintenance and Care	36	5.7 V-Belt Drive	58	
1.7 Labels at the Machine	13	5.1 Hako System Maintenance	36	5.8 Electric System	59	
2 First Operation	17	5.2 Maintenance document	37	5.9 Special Equipment and Spare Parts	61	
2.1 Instruction	17	5.3 Maintenance Schedule	38	EC-Declaration of Conformity	63	
2.2 Initial charging procedure	17	5.4 Battery System	44			
2.3 Before Taking into Operation	17	5.4.1 Low Discharge Signal Sender . .	45			
2.4 Start Machine	17	5.4.2 Battery Charging Status Indicator	45			
2.5 Operation	18	5.4.3 Hourmeter	45			
2.6 Machine stopping and parking	18	5.4.4 Setting Other Battery Types . . .	45			
2.7 After work	18					
2.8 Transport rides and Towing	19					

Safety information

1 Safety information

1.1 Safety and Warning Symbols

All paragraphs in this manual referring to your personal safety, the safety of your machine and the environment protection are attributed one of the following warning symbols:

Symbol	Hazardous for ...	Description
Safety Provisions 	persons and goods	Safety Provisions in dangerous situation caused by misuse inaccurate adherence of instructions or prescribed work routine.
CAUTION 	the machine	important information on handling the machine in order to maintain operability.
Ecological hazard 	the environment	due to use of substances representing an inherent danger to health of environment

Safety information

1.2 General Provisions

- Apart from the provisions contained in this instruction manual, the general safety provisions and the accident prevention regulations as imposed by law have to be complied with.
- Before taking your machine into operation, carefully read the instruction manual and comply with all points mentioned there during work.
- Persons being trained by qualified Hako technicians only are authorised to operate, service and repair the machine.
- This vehicle is not intended to be used by persons (including children) with limited physical or mental capabilities or persons without sufficient experience and ability.
- You are advised to thoroughly study the safety instructions since precise knowledge only helps avoiding errors during operation of the machine and thus guarantee faultless usage of the machine.
- The operating instructions have to be at hand at the place of use of the machine, and therefore have to be kept readily available at the machine.

- When selling or letting the machine for rent, hand out these documents to the new owner/operator and have the transfer certified!
- The warning and instruction plates attached to the machine contain valuable advice about safe operation. Immediately replace incomplete or illegible labels.
- As far as safety standards are concerned, spare have to equal genuine spare parts!
- Keep clear of hazard zone of the Sweepmaster B1200 RH.
- Only use a mobile phone when the machine standing still.
- Passenger transport is not admitted.

1.3 Provisions for Operation

- Before taking into operation, check the machine for operational safety! Immediately remedy malfunctions!
- It is indispensable for the operator to get acquainted with all attached implements and controls as well as with their function before operation begins. Once you have started to work, no time will be left to do so!
- When working with the machine use firm and skid proof shoes.

- The machine may be used only on such surfaces clearly specified by the owner or his authorised representative.
- When working with the machine take notice of third persons, especially children.
- The machine is not designed for collecting hazardous, inflammable or explosive dusts or substances.
- This machine must not be used as dust-evacuating machine with dust filter insert (separator) to collect dusts which are hazardous to health.
- Usage of the machine in explosive areas is prohibited.
- Pull the key switch to avoid unauthorized use of the machine.
- Before commencing work, the operator has to make sure that the machine and its accessories are in proper and safe condition. Machines with known defects must not be used.
- Before operation of the machine, adjust driver's seat such that complete visibility of the riding track and the rear working area is given!
- For safety reasons, the driver's seat is equipped with a seat contact

Safety information

switch. Function of this contact switch must not be bypassed!

- The seat contact switch will controlled electronically. Any manipulation to result in automatically blocking of the machine.
- Disengage all drive systems before switch-on the machine.
- The machine may be started, run and stopped by a person seated only.
- Never let the machine run in indoor areas! Intoxication hazard!
- Provide for sufficient ventilation when sweeping indoors (dust and combustion gas). Intoxication hazard!
- Always adapt the driving speed to the ambient conditions and the loading state.
Compared to four-wheeled vehicles, driving stability of three-wheeled vehicles is reduced, therefore:
Abrupt steering manoeuvres at higher speed or negotiating curves at high speed may cause tipping of the articulated vehicle.
Do not turn at slopes but on level ground only
Ride up- and downhill straight.

Avoid taking sudden curves when riding up- or downhill or across to the slope.

In slope there is tilting danger.

- The machine may be used only for operation on areas with a maximum inclination of up to 16 %.
- Do not exceed the admissible total weight and the admissible axle load limits. Check the dirt hopper filling level frequently.
- Before lifting or lowering the dirt hopper make sure that no persons, animals or other obstacle are in the area of operation.
- Pinching and shearing hazard. Provide for required safe distance before lifting or lowering the dirt hopper.
- It's only allowed to lift up the dirt hopper in immediately nearness of the container.
Emptying the dirt hopper on level and solid ground.
- Do not sweeping when the dirt hopper is lifted.
- By emptying the dirt hopper pay attention to bystanders.
- Proceed to filter shaking only if the dirt hopper is in closed position.

- Pay attention to hot parts for example cooling water, tubes of the exhaust etc..

1.4 Maintenance instructions

- The daily and weekly maintenance and repair task must be performed by a qualified operator. For any maintenance and repair work beyond please contact your local Hako service centre.
- Observe the maintenance activities and intervals set out in the instruction manual.
- Maintenance and repair work may be carried out only by means of appropriate tools.
- Have the machine checked for safe condition in the sense of the Accident Prevention Regulation by an expert at regular intervals (recommendation: at least once yearly) as well as after modifications or repair.
- Spare parts have to equal the technical requirements as specified by the manufacturer! Genuine spare parts guarantee compliance with these requirements.
- Use of other than the sweeper rollers and side brooms approved by the

Safety information

manufacturer is not admitted (see technical data) since use of other sweeper rollers and side brooms may affect your safety.

- Use of other than the oilfilters approved by the manufacturer is not admitted (see technical data) since use of other air- and oilfilters may affect your safety.
- Stop machine before proceeding to inspection and maintenance work. Pull the key.
- Proceed to cleaning of the dirt hopper in regular intervals to preclude formation of bacterial deposits.
- The machine is splash-proof (IPX3). Cleaning the machine by means of high-pressure cleaning equipment or by vapour jet is prohibited.
- Turn off the machine before transporting them.
- After having jacked the Sweepmaster B1200 RH by means of a car lifter, additionally support the machine adequately.
- No person is allowed to be in the jacked or lifted-up Sweepmaster B1200 RH.
- Before changing wheels protect the machine against rolling by placing

wedges.

Proceed to wheel changing when the machine is on level and solid ground.

- Do not remove, install or repair a tire on the rim. Contact a tire workshop for works at tires and rims. Such workshops have qualified personnel as well as special safety tools at disposal.
- Do not proceed to welding, boring, sewing or grinding at the vehicle's frame. Only Hako-workshops are authorized to replace damaged parts.
- Use genuine fuses only. Use of higher-level fuses may damage the electric system. Risk of fire.
- When working at the electric system disconnect the the battery plug.
- Do not keep batteries discharged for a longer period, always recharge them as soon as possible.
- Top with distilled water only. Never refill battery acid in battery cells of perfect condition.
- Keep batteries dry and clean and clear of soiling such e.g. metallic dust to avoid leakage current.
- Battery acid is highly caustic (keep clear of children).
When checking the battery acid lev-

el, wear safety glasses. If acid splashes get into the eyes rinse with clear water for 15 minutes and contact a doctor immediately.

Use appropriate protective means (e.g. protective gloves or finger-stalls) when handling battery acid. Do not use open flames (explosion hazard).

- Pinching and shearing hazard by fitting, removal and change of the battery.
- All liquids escaping under high pressure (such as e.g. hydraulic liquid) may penetrate the skin and cause heavy injuries. Contact a doctor immediately in order to avoid infections. Take all precautions before draining boiling oil - burning hazard.
- Inspect the braking system at regular intervals. Hako-workshops or approved brake service centres only are authorized to proceed to adjustment or repair work of the brake system.
- Inspect the hydraulic system at regular intervals. Hako-workshops only are authorized to proceed to adjustment or repair work of the hydraulic system.

Safety information

- Check hydraulic hoses and lines for leakage or damages in regular intervals. Replace defective hoses and lines immediately.
- Provide for sufficient ventilation of areas where batteries are charged. – Explosion hazard!
Open seat hood by loading the batteries.

1.5 Specific Hazards

Safety equipment

- Do not operate the Sweepmaster B1200 RH without safety equipment being installed (all cover parts of the machine).

Electric system

- Only use genuine fuses with prescribed connecting load.
- In case of malfunction of the electric system, immediately shutdown machine and remedy.
- Qualified personnel only is authorised to proceed to works at the electrical equipment and only according to electro-technical rules.
- Inspect/check the electrical equipment of the machine at regular intervals. Immediately remedy defects such e.g. loose connections or scorched cables.
- Respect the operating instructions of the battery manufacturer.
- Never place metal objects or tools on batteries - short-circuit hazard!

Safety information

1.6 Information for Protection of Environment

- For safe use of substances inheriting a danger to health and environment specific knowledge is required.
- During maintenance and repair, all operating media have to be collected in adequate receptacles. Provide for disposal in compliance with the legal provisions according to the Waste Disposal Act and the Used Oil Act.
- Do not let leaking oil, lubricants or other substance penetrate the soil. Danger of ground water soiling. Wipe away spilled fluids and provide for disposal according to the regulations.
- Depending on the filtered substances, used filter inserts are considered special waste in most cases and have to be disposed of accordingly.
- Batteries contain highly caustic sulphuric acid. Batteries have to be handled with utmost caution. Old batteries are considered special waste and have to be disposed of accordingly.
- Used batteries labelled as recyclable contain reusable economic goods.

According to the crossed dustbin label these batteries must not be added to the normal waste. Provide for agreement with the Hako contract dealer on return and disposal according to § 8 BattV.

Safety information

1.7 Labels at the Machine

The following safety and information labels are legibly attached to the vehicle. Replace missing or illegible labels immediately.

Hako nameplate front (Fig. 1/1) and rear (Fig. 2/1)

Vehicle identification number (Fig. 1/2)



Instruction manual (Fig. 1/3)



Key switch (Fig. 1/4)

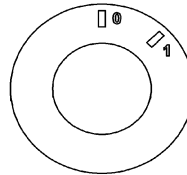

Brake (Fig. 1/5)

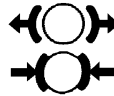

Parking brake (Fig. 1/6)



Folding apron (Fig. 1/7)



High-pressure cleaner
Steam cleaner (Fig. 1/8)



Lifted-up disposal function (Fig. 1/9)

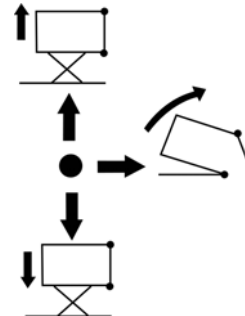

Safety information

Sound power
Rise (Fig. 1/10)

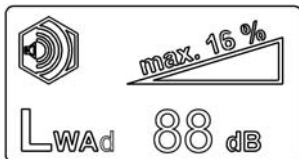

Adjust sweeping track side broom
(Fig. 1/11)



Maximum speed (Fig. 1/12) and (Fig. 2/7) (option)



Pinching hazard (both sides) (Fig. 2/2)



Sweeper roller wearing take-up
(Fig. 2/3)



Rotating parts (Fig. 2/4)



Hydraulic fluid (Fig. 2/5)



Type name(Fig. 2/6)

Sweepmaster B1200 RH

Safety information

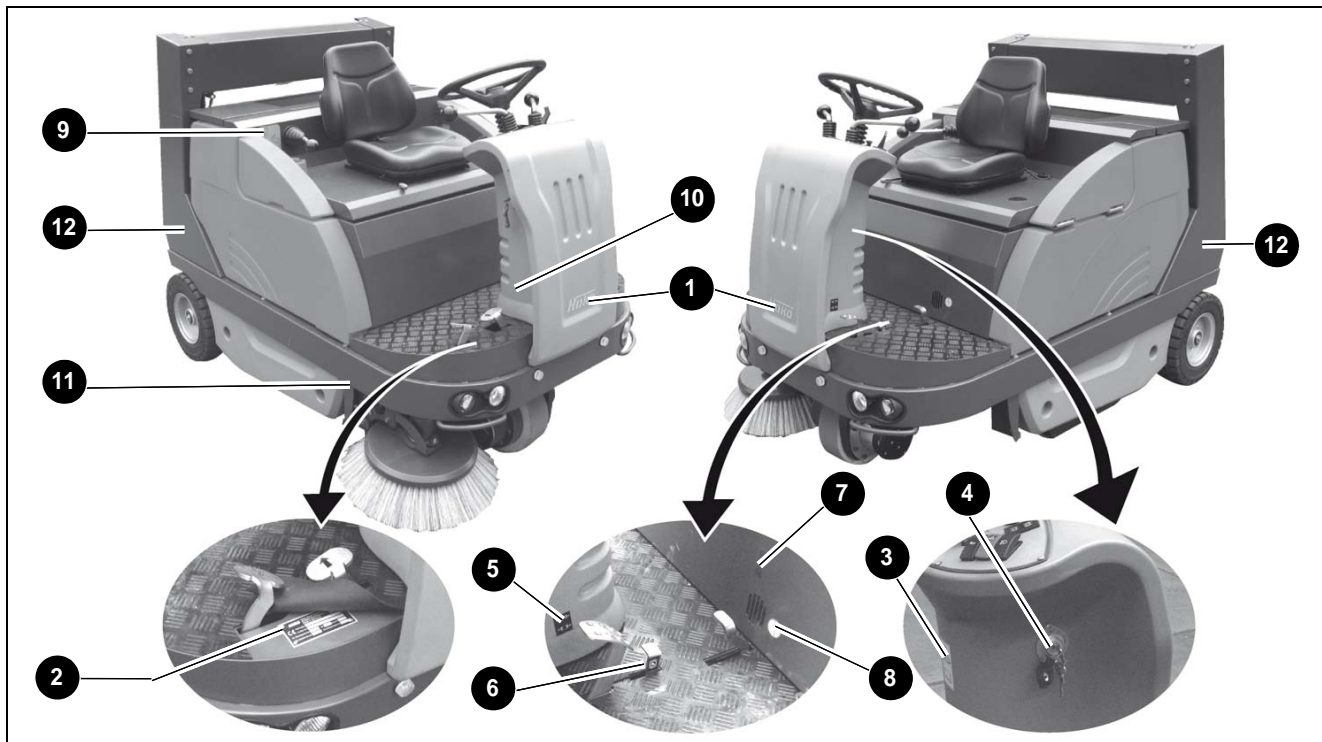

Fig.1

Safety information

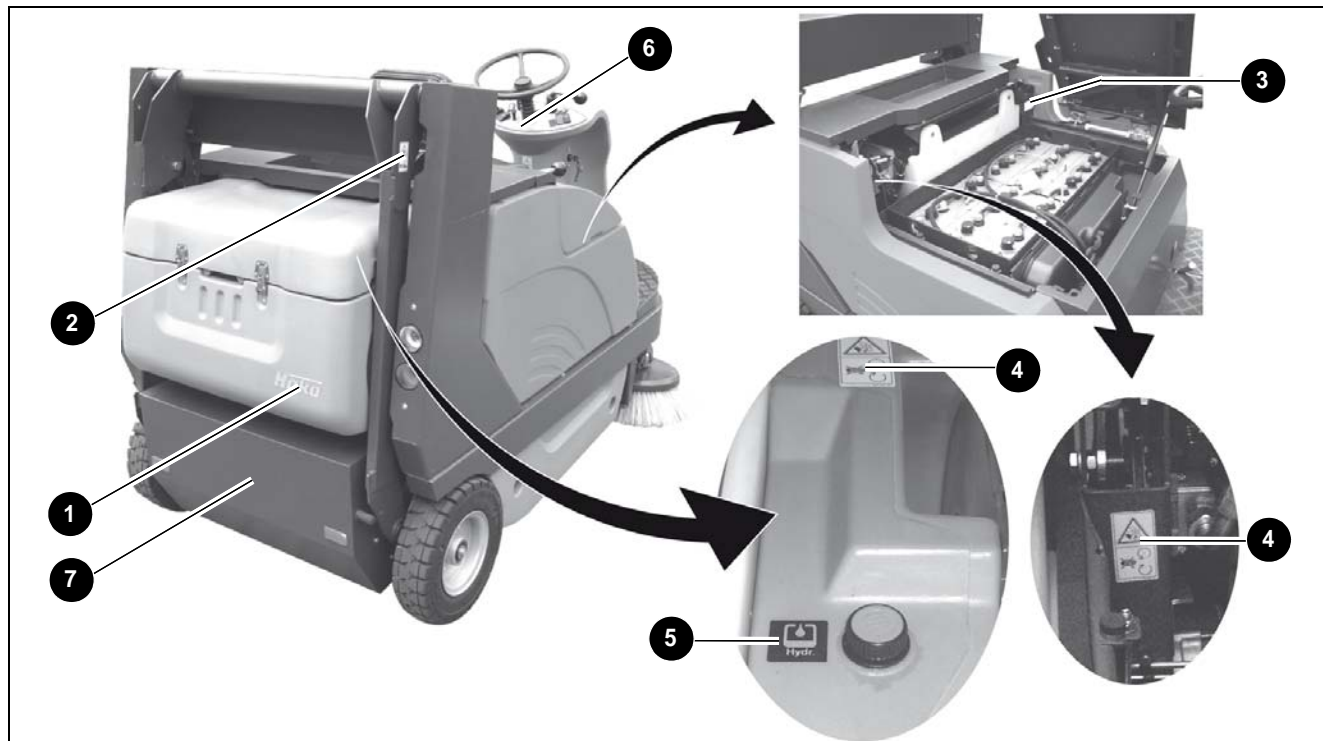

Fig.2

First Operation

2 First Operation

2.1 Instruction

Instruction is required before first operation. First instruction into handling of the machine must be held by a qualified person sent by your local Hako contract dealer. Your Hako dealer will be informed by the manufacturer upon delivery of the vehicle and will contact you to make a date for instruction.

2.2 Initial charging procedure



Before first operation of the machine, fully charge the battery with an initial charging procedure and comply with the operating instructions of the charger as well as with those of the battery manufacturer. Hako cannot be held liable for damages resulting from the fact that the initial charging has not or insufficiently been done.

2.3 Before Taking into Operation

Proceed to the following inspections before taking the machine into operation:

1. Check parking site for signs of leakage. Hoses, lines and tanks must be free from any leakage or damage.
2. Open seat hood.
3. Check charge of battery and charge if required.
4. Close seat hood.

2.4 Start Machine



Before starting the machine you are advised to read and comply with the Provisions of Operating from Safety Information chapter!

Before starting the machine, subsequently actuate the following control elements:

1. Set all operating levers and switches to neutral.
2. Secure the vehicle by engaging the parking brake.
3. Turn key switch and start machine.
 - After the machine has switched on, the charge control display (TSG) is lighting up by full charging battery.



Do not use the Sweepmaster B1200 RH at ambient temperatures of more than 40°C. Do not switch on the machine at temperatures of 0°C or less.



Its not possible to switch on the machine, when the accelerator pedal is linked.

First Operation

2.5 Operation

Proceed to the following to set the machine into operation:

1. Check the machine, see paragraph 2.3 - Before Taking into Operation.
2. Start vehicle, see paragraph 2.4.



In initial position, vacuuming is activated. Use the operating draw if the collected dirt is wet.

3. Lower sweeper roller and side broom.
4. Release parking brake.
5. Slowly depress drive pedal until desired speed has been attained.
6. Check filling level of the dirt hopper and empty if required.
7. Operate shaking installation regularly for cleaning the filter.

2.6 Machine stopping and parking

1. Release drive pedal which returns automatically in neutral position and the machine slows down.
2. Actuate parking brake.
3. Lift sweeper roller and side broom.
4. Switch machine off.



Slowing down the Sweepmaster B1200 RH is possible by applying opposite forces with the drive pedal or by using the service brake.



When leaving the machine unattended, pull key switch in order to preclude unauthorized use.

2.7 After work

1. Ride machine to suitable site for cleaning.
2. Stop machine, lift sweeper roller and side broom.
3. Start shaking procedure.
4. Empty dirt hopper, see operation chapter 3.2.2.
5. Clean machine.



Do not clean the electrical parts by means of high-pressure cleaning equipment.

First Operation

2.8 Transport rides and Towing Transport rides

Before transporting the Sweepmaster B1200 RH on other vehicles, engage the parking brake and secure the machine by placing wedges at the wheels and by straps on the tie-down points front (Fig. 3/1) and rear (both sides) (Fig. 3/2).



For safety reason, by activated machine and by leaving the driving seat is resounding a warning signal.

Towing

Lift up the front wheel when towing the machine.

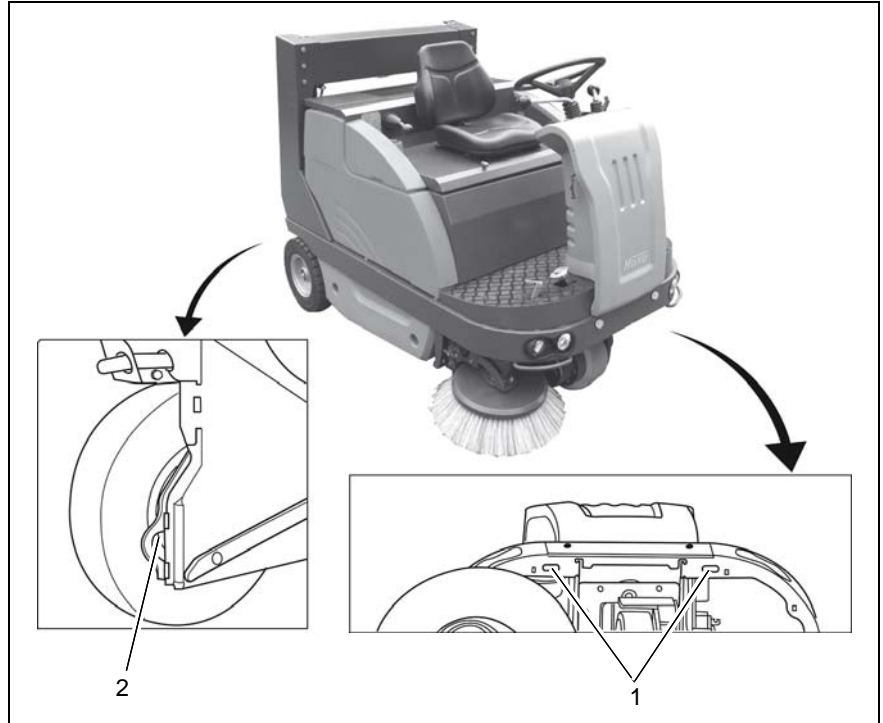

Fig.3

3 Operation

3.1 Working Procedure

General

The Sweepmaster B1200 RH sweeper has been exclusively designed for collecting dry and moist matter from floor surfaces in e.g. factories, storage buildings, parking grounds and pedestrian areas.

Functional Description

The side broom (Fig. 4/1) is used to collect dirt at corners and borders and to enlarge the working width as well as to increase the area performance on large surfaces. The sweeper roller (Fig. 4/2) casts the dirt overhead into the dirt hopper (Fig. 4/3). The collected fine dust is evacuated by the suction fan and separated by a filter system (Fig. 4/4). The air returned into the environment is clean. Dirt disposal at the Sweepmaster B1200 RH is realized via lift-up disposal (lift-up height > 1420mm) directly into standard waste container.

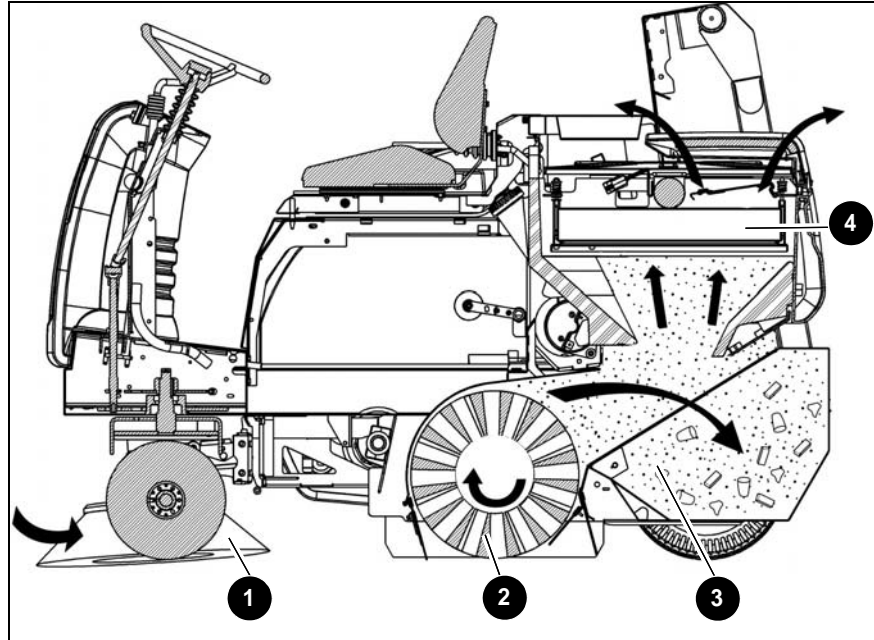

Fig.4

Operation

3.1.1 Sweeper Roller

The sweeper roller (Fig. 4/2) is equipped with 12 rows of bristles arranged in v-shape.

The sweeper roller width amounts to 800 mm and its diameter to 430 mm. The operator lifts and lowers is by hand lever (Fig. 5/1).

3.1.2 Side Broom

The standard version, the side broom (Fig. 5/2) is located at the front right of the machine. The operator lifts and lowers is by hand lever (Fig. 5/3).

The swinging area of the side broom arm is limited by stops.

For special application, fitting of a second side broom at the left side is possible.

3.1.3 Steering

Steerage is effectuated mechanically from steering wheel to front wheel via chain. This chain is to be re-adjusted as required.

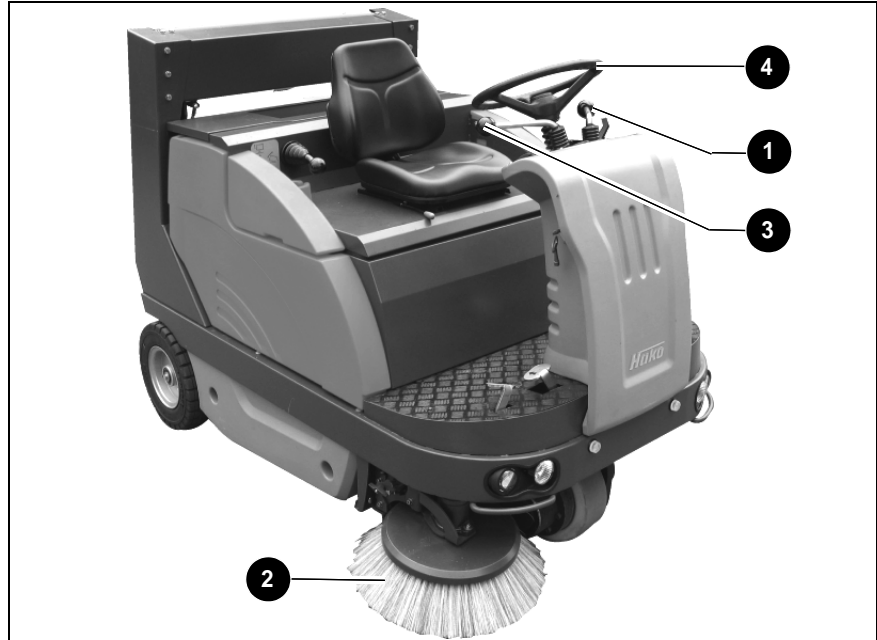

Fig.5



Any work at the steering has to be executed by authorized Hako-service-workshop only.

Operation

3.1.4 Filter System Dust Evacuation

The filter system is located in the filter case (Fig. 6/1) above the dirt hopper (Fig. 6/2). The suction fan transports the fine dust raised by the sweeper roller to the plate filter (Fig. 6/3) where it is separated. The fine dust sets at the outside of the filter blades.



In case of heavy dusty sweeping dirt, check and clean the plate filter (Fig. 6/3) at regular intervals.

3.1.5 Shaking System

Due to normal working vibration the set dust from the plate filter (Fig. 6/3) partly falls off into the dirt hopper (Fig. 6/2). To ensure working in a dustfree ambiance, actuate the shaking system regularly, or after request by the control lamp (Fig. 10/5) at the latest.



Fig.6

Operation

3.1.6 Brake

The Sweepmaster B1200 RH is equipped with a service brake. This brake has been constructed as shoe brake and equally serves as parking brake. It is located in the rear wheels and is actuated via cables. Two special adjustment screws (Fig. 7/2) are located in front of the chassis, behind the front cover (Fig. 7/1).



Any work at the braking system has to be executed by authorized Hako-service-workshop only.

3.1.7 Travel Drive Assembly

The Sweepmaster B1200 RH are equipped with a electric drive assembly.

3.1.8 Hydraulic System

The hydraulic system existing of hydraulic valves, hydraulic pump with hydraulic fluid tank (Fig. 7/3) and serves the operation of the lifted-up disposal and the side broom.

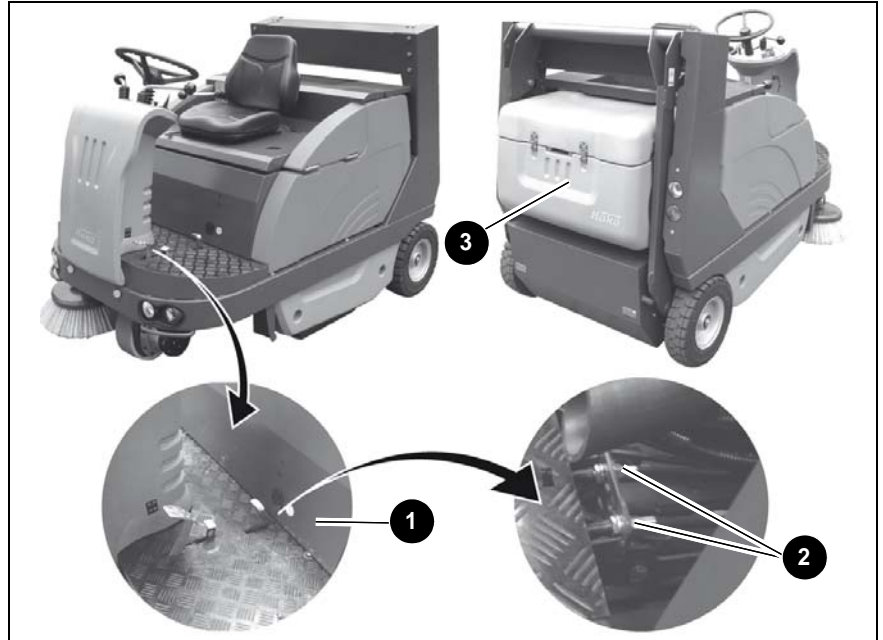

Fig.7

Operation

3.2 Operating Elements

- 1 Actuator for folding apron
- 2 Service brake lock
- 3 Service brake / parking brake pedal
- 4 Drive pedal, reverse
- 5 Drive pedal, forward
- 6 Control panel
- 7 Seat adjustment
- 8 Lever for dirt hopper (lifting-lowering-swinging)

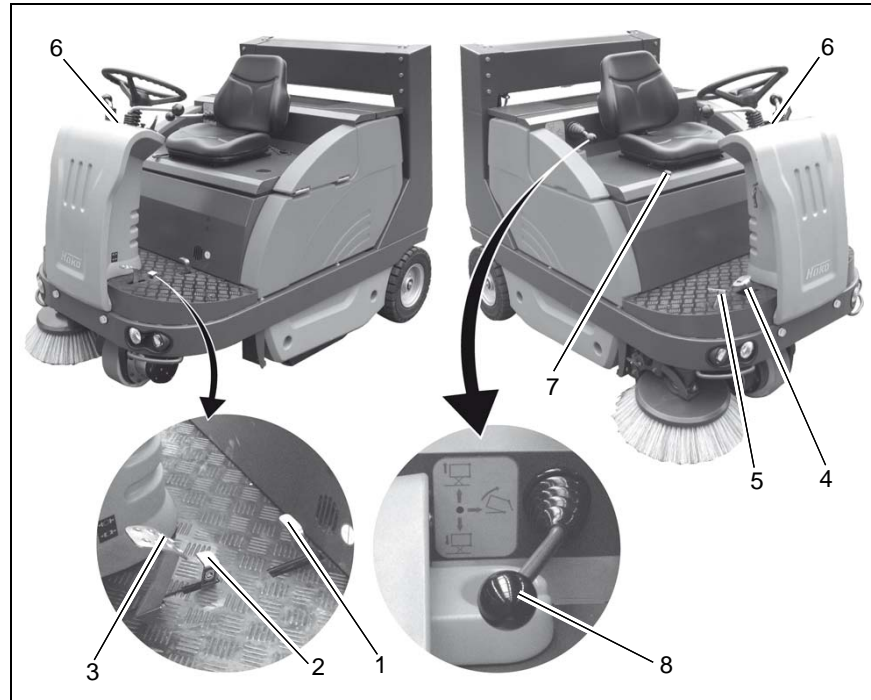

Fig.8

Actuator for folding apron (Fig. 8/1)

To open and close the folding apron for collecting coarse dirt during sweeping drive.

Service brake / parking brake lock (Fig. 8/2)

To lock the service brake / parking brake. Operate pedal and fix with lock. The service brake is working then as parking brake. The lock released by pushing service brake pedal (Fig. 8/3).

Service brake / parking brake pedal (Fig. 8/3)

Serves for operating the service brake on the rear wheels. Simultaneously actuate service and parking brake before leaving the machine.

Drive pedal, forward (Fig. 8/5)

To change direction to forward ride with continuous regulation of riding speed at the same time. If the driver releases the pedal it returns to initial position and the machine slows down to standstill.

Drive pedal, reverse (Fig. 8/4)

To change direction to reverse ride with continuous regulation of riding speed at the same time. If the driver releases the pedal it returns to initial position and the machine slows down to standstill.

Control panel (Fig. 8/6)

Refer to chapter „control Panel“.

Seat adjustment (Fig. 8/7)

To adjust the seat position to drivers of different height. Adjust the seat so as to allow the driver being comfortably seated and attaining all elements required for operation.

- Adjust seat lengthwise:
push lever slightly to the right and displace seat forwards or backwards to the required position.
Then let the lever catch again.

Lever for dirt hopper (Fig. 8/8) (lifting-lowering-swinging)

Lever for lifting-lowering-swinging the dirt hopper.

For lifting and lowering pull simultaneously lever for release of lifted-up disposal function (Fig. 9/1).

Swinging follows without operating of the lever (Fig. 9/1).

Simultaneously actuate lever for release of lifted-up disposal function, lever for sweeper roller (see chapter „Control Panel“), he serves releasing the dirt hopper for lifting and lowering. Swinging of the dirt hopper without lever for release for lifted-up disposal function.

Operation

3.2.1 Control Panel Sweepmaster B1200 RH

- 1 Sweeper roller lever and release of lifted-up disposal function
- 2 Side broom lever or rather for side broom and sweeper roller
- 3 Suction fan / shaking system knob
- 4 Control lamp, shaking system
- 5 Control lamp, direction indicator (Option)
- 6 Hourmeter / Charge control display (TSG)
- 7 Control lamp, parking brake
- 8 Horn
- 9 Key switch
- 10 Indicator lever (Option)
- 11 Lighting (Option)
- 12 Warning light (Option)
- 13 Rotating beacon (Option)
- 14 Side broom left (Option)

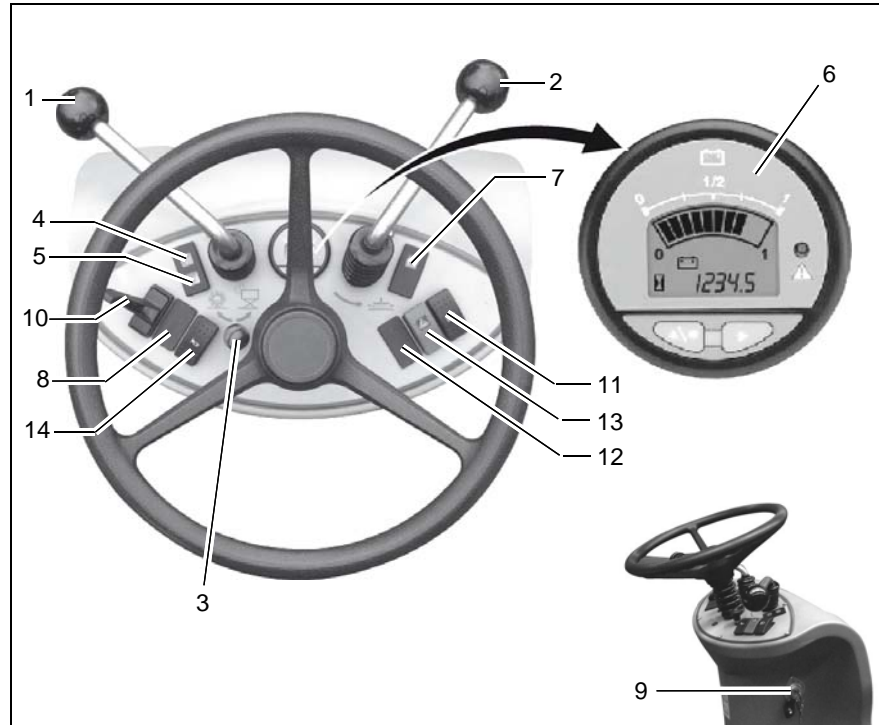
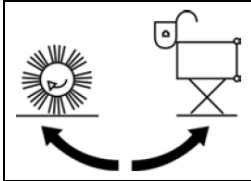

Fig.9

Operation



Sweeper roller lever and lifted-up disposal (Fig. 9/1)

Two-Hand-Operation.

For lifting, lowering, swinging, to switch on and off the sweeper roller and to release of lifted-up disposal.

- Sweeper roller lowering and switch on = push lever
- Sweeper roller lifting and switch off = pull in middle position
- Release of lifted-up disposal function = pull lever

(see chapter „Emptying of the Dirt Hopper“).



Lifting and turn off the sweeper roller, if the lever for the right side broom is in lifting position.

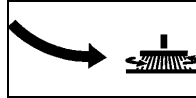

Side broom lever (Fig. 9/2)

To lift and lower the side broom or lower and turn on the side broom and sweeper roller in one process (Fig. 9/1).

- Lower side broom = push lever.
- Lift side broom = pull lever.

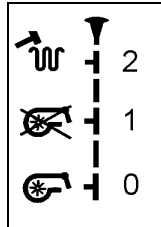

Suction fan / shaking system (Fig. 9/3)

Knob position (from bottom to top):

- 0 Activated vacuuming function
- 1 Deactivated vacuuming function
- 2 Shaking system ON (pull knob to stop and then release)

If the yellow control lamp (Fig. 9/5) lights actuate the shaking system (position 2).

In this position, the shaking system is operable and proceeds to jolting in 7 repeated intervals.



After jolting, the knob is to be kept in position 1 for about 25 seconds.

Operation



Control lamp, shaking system (Fig. 9/4)

Proceed to jolting of the filter system upon lighting of this control lamp by actuating the knob (Fig. 9/4) in position 2.



The control lamp flashes during the shaking procedure and extinguishes after filter has been cleaned. Jolting is effectuated in 7 intervals.

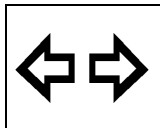

Control lamp, direction indicator (Option) ((Fig. 9/5)

Indicate, if using the indicator lever, the direction.



Hourmeter Charge control display (TSG) (Fig. 9/6)

Indicates the operating hours. The counter works only if the driver is seated and the machine is running. Charge control display see chapter 5.4 Battery System.



Control lamp, parking brake (Fig. 9/7)

Lights upon actuation of the parking brake. Extinguishes upon release of the parking brake.



Horn (Fig. 9/8)

An acoustic signal sounds upon actuation of this button.

Operation

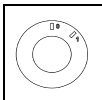

Key switch (Fig. 9/9)

To switch on and off the machine and to secure it against unauthorised use.



For safety reason, by activated machine and by leaving the driving seat is resounding a warning signal.

Indicator lever (Option) (Fig. 9/10)

Indicate changing of direction

- Lever down = to left.
- Lever up = to right.



Lighting (Option) (Fig. 9/11)

To switch the driving headlight ON/OFF.



Warning light (Option) (Fig. 9/12)

Use this switch by a technical defect, if is impossible to move the machine. Lighting flashes ON/OFF.



Rotating beacon (Option) (Fig. 9/13)

To switch the rotating beacon ON/OFF.



Side broom left (Option) (Fig. 9/14)

For special application, fitting of a second side broom at the left side is possible.

- Switch actuate = side broom lowering and turning on.
- Switch not actuate = side broom lifting and is laying up.

Operation

3.2.2 Emptying of the Dirt Hopper

Proceed to emptying of the dirt hopper as follows:

- Lift and switch off side broom and sweeper roller.
- Proceed to shaking of the filter system.
- Lift dirt hopper as follows:
Pull lever for dirt hopper (Fig. 10/1) upwards and simultaneously pull the lever for sweeper roller and release for lifted-up disposal (Fig. 10/2) in arrow direction.
- Bring dirt hopper for disposal in suitable height position.
- Back the Sweepmaster B1200 RH until the dirt hopper is positioned above the container.
- Pull lever for dirt hopper (Fig. 10/1) in arrow direction, dirt hopper is swinging in emptying position.
- Forward the Sweepmaster B1200 RH after complete emptying.



Caution by driving away, if dirt hopper is towering in the container:
Hazard of damaging!

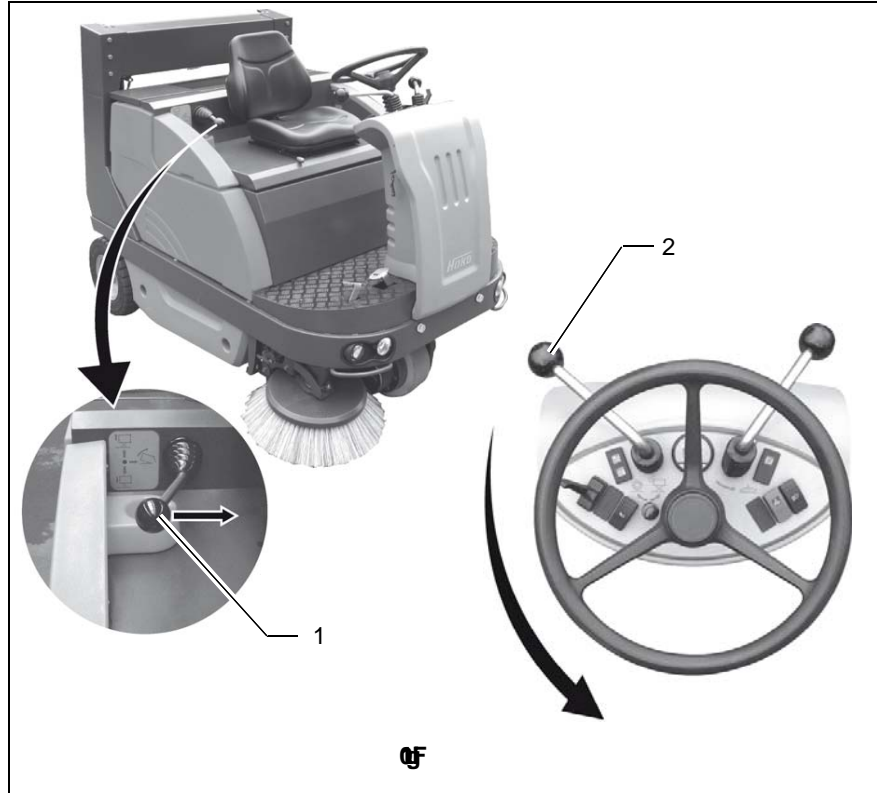

Operation

- Lower dirt hopper as follows:
Pull lever for dirt hopper (Fig. 10/1) down and simultaneously pull the lever for sweeper roller and release for lifted-up disposal (Fig. 10/2) in arrow direction.
- The dirt hopper is swinging automatically in starting position by lowering.
- Dirt hopper is again in working position.



The operation of lifted-up disposal function is blocked as long as sweeping function is ON.



Do not switch on sweeper roller when dirt hopper lifting out.



Riding with the lifted dirt hopper reduces stability of the machine significantly. For this reason, do not lift the dirt hopper but just before emptying. Before lifting the dirt hopper, the operator has to make sure that no persons or objects are behind or next to the machine. Stop the machine on level ground before lifting the dirt hopper.



When the dirt hopper is lifted, the operator has to ride the machine slowly.



Keep clear of the hazard zone! Pinching and shearing hazard. Provide for required safe distance before lifting or lowering the dirt hopper



The dirt hopper is approved only for max. filling of 130 litres but not more than a weight of 220 kg.



Do not move the machine during the lifting procedure.



Clean the dirt hopper in regular intervals.

Technical Data

4 Technical Data

Dimensions and weights		
Length with side broom	mm	1998
Width without side broom	mm	1142
Width with 1 side broom	mm	1142
Width with 2 side brooms	mm	1142
Height above driver's seat	mm	1520
Dead weight	kg	735
Admissible total weight	kg	1395
Driving and sweeping performance		
Forward speed	km/h	0-8
Reverse speed	km/h	0-4
Sweeping speed up to (4 km/h recommended)	km/h	8,0
Sweeping track w/o/with 1 side broom	mm	800 / 1150
Sweeping track with 2 side brooms	mm	1470
Theoretical sweep. perf. with 1 or 2 side brooms	m ² / h	9200/11700
Theoretical sweep. perf. without side broom	m ² / h	6800
Gradability (max. 1 min)	%	16

Technical Data

Filter system		
Filtering surface	m ²	5,0
Plate filter	peaces	1
Sweeper roller		
Length / diameter	mm	800 / 430
Wearing limit	mm	350
Speed	1/min	500+/-20
Sweeping track	mm	50+10
Quantity of bristle rows		12 v-shaped
Serial bristling		PES
Ground clearance of sealing		
Sealing strips, left / right / rear	mm	1 / 1 / 4
Sealing strip, front		lying on the bottom
Side brooms		
Diameter	mm	600
Speed	1/min	85+/-4
Serial bristling		PES

Technical Data

Dirt hopper Hopper capacity	litre	130
Drive wheels wheel front, solid rubber tyres Solid rubber tyres (rear)		Wheel bandage: D=300/B=100 4.00-8
Hydraulic system Travel drive assembly Haydraulic fluid, e.g. Mobiloil Hydraulic tank, capacity Fluid filter cartridge	litre order-no.	DTE 15 M (or an equivalent oil) 13 01133510
Electric system Supply voltage Drive (recirculated capacity) Drive of sweeper roller (recirculated capacity) Drive of side broom (recirculated capacity) Drive of exhaust fan (recirculated capacity) Degree of protection against infiltration of water	V KW KW KW KW	24 1.875 1.25 1.25 1.25 IPX3

Technical Data

<p>Noise emission</p> <p>The sound pressure level (L_{pA}) (at the ear of the operator) measured according to DIN IEC 60335-2-72 under normal working conditions:</p> <p>Measurement inaccuracy (K_{pA}):</p> <p>Sound power level ($L_{WA,d}$) measured according to DIN EN 60335-2-72 under maximum working conditions:</p> <p>Sound power level ($L_{WA,d}$) measured according to DIN EN 2000/14/EG under maximum working conditions:</p>	<p style="text-align: center;">dB (A)</p> <p style="text-align: center;">dB (A)</p> <p style="text-align: center;">dB (A)</p> <p style="text-align: center;">dB (A)</p>	<p style="text-align: center;">71</p> <p style="text-align: center;">2</p> <p style="text-align: center;">88</p> <p style="text-align: center;">88</p>
<p>Vibration</p> <p>The weighted effective value of acceleration, measured in accordance with ISO 5349-1, to which the upper parts of the body (hand-arm) are exposed under normal working conditions:</p> <p>The weighted effective value of acceleration, measured in accordance with ISO 2631-1, to which the body (feet-seat) is exposed under normal working conditions:</p>	<p style="text-align: center;">m/s^2</p> <p style="text-align: center;">m/s^2</p>	<p style="text-align: center;">2,5</p> <p style="text-align: center;">0,5</p>

5 Maintenance and Care

General



Before proceeding to maintenance and care work you are advised to read and comply with the Safety Information chapter!

Compliance with the recommended maintenance works will give you the certitude of always having a reliable machine at disposition.

Daily or weekly maintenance and repair works may be executed by the driver/operator having been trained accordingly. Further Hako system maintenance works have to be executed by qualified personnel only. Please contact your local Hako Service Centre or Hako contract dealer. We cannot be held liable for damages resulting from non-compliance with these instructions. Please indicate the machine's serial number with any enquiry or spare part order, see paragraph 1.7 - Nameplate.

5.1 Hako System Maintenance

The Hako System Maintenance:

- guarantees reliable operability of the Hako machines (preventive maintenance)
- minimizes operating costs, repair costs and maintenance costs
- ensures long service life and operability of the machine

The Hako System Maintenance is structured in separate modules and determines specific technical works to be executed as well as the intervals for such maintenance works. For any specific maintenance type, the replacement parts are determined and listed in spare part kits.

Hako System Maintenance K:

To be performed by the customer in accordance to the maintenance and care instructions contained in the operating instructions (daily or weekly). The driver/operator will be instructed upon delivery of the machine.

Hako-System Maintenance I :

(after 50 hours of operation - einmalig)
To be performed by qualified personnel of authorised Hako Service Centre.

Hako-System Maintenance II:

(every 125 hours of operation)
To be performed by qualified personnel of authorised Hako Service Centre in accordance with the machine-specific system maintenance including spare part kit.

Hako-System Maintenance III:

(every 250 hours of operation)
To be performed by qualified personnel of authorised Hako Service Centre in accordance with the machine-specific system maintenance including spare part kit.

Hako-System Maintenance S:

(every 500 hours of operation safety check)
To be performed by qualified personnel of authorised Hako Service Centre in accordance with the machine-specific system maintenance including spare part kit. Execution of all safety-relevant inspections according to UVV-BGV-TÜV-VDE as prescribed by law.

Maintenance and Care

5.2 Maintenance document

<p style="text-align: center;">Handing over</p> <p>Upgrade Test drive Handing over to the customer Instruction carried out on: at _____ operatin hours</p>	<p style="text-align: center;">Hako-System-Maintenance I 50 operating hours Workshop stamp</p> <p>carried out on: at _____ operatin hours</p>	<p style="text-align: center;">Hako-System-Maintenance II 125 operating hours Workshop stamp</p> <p>carried out on: at _____ operatin hours</p>	<p style="text-align: center;">Hako-System-Maintenance III 250 operating hours Workshop stamp</p> <p>carried out on: at _____ operatin hours</p>
<p style="text-align: center;">Hako-System-Maintenance II 375 operating hours Workshop stamp</p> <p>carried out on: at _____ operatin hours</p>	<p style="text-align: center;">Hako-System-Maintenance III+S 500 operating hours Workshop stamp</p> <p>carried out on: at _____ operatin hours</p>	<p style="text-align: center;">Hako-System-Maintenance II 625 operating hours Workshop stamp</p> <p>carried out on: at _____ operatin hours</p>	<p style="text-align: center;">Hako-System-Maintenance III 750 operating hours Workshop stamp</p> <p>carried out on: at _____ operatin hours</p>
<p style="text-align: center;">Hako-System-Maintenance II 875 operating hours Workshop stamp</p> <p>carried out on: at _____ operatin hours</p>	<p style="text-align: center;">Hako-System-Maintenance III+S 1000 operating hours Workshop stamp</p> <p>carried out on: at _____ operatin hours</p>	<p style="text-align: center;">Hako-System-Maintenance II 1125 operating hours Workshop stamp</p> <p>carried out on: at _____ operatin hours</p>	<p style="text-align: center;">Hako-System-Maintenance III 1250 operating hours Workshop stamp</p> <p>carried out on: at _____ operatin hours</p>

Maintenance and Care

5.3 Maintenance Schedule Hako-System Mainten. Customer

The following maintenance works are to be performed by the customer.

Discription of task	Interval
	daily
Check dirt hopper (dustbin), and empty if required	o
Operate shaking system	o
Test drive and function test	o

Maintenance and Care

Hako-System Maintenance Customer

The following maintenance works are to be performed by the customer.

Discription of task	Interval
	weekly
Check acid level, fill up distilled water if required (by end of charge only)	o
Dirt hopper: Check sealing and replace if required	o
Check sweeper roller for wearing or foreign particles, re-adjust or replace if required	o
Check electrical system	o
Check hydraulic fluid level, refill if required	o
Check side broom for wearing, re-adjust and replace if required	o
Check folding apron for wearing and damaging, re-adjust and replace if required	o
Visual check of engine and hydrailic system for oil leakage	o
Clean machine	o
Test drive and function test	o

Maintenance and Care

Hako-System Maintenance I

The following maintenance works are to be performed by authorized HakoService-Centre.

Discription of task	Interval
	after 50 hours of operation (uniquely)
Check sealings at filter system	o
Visual check of V-belts	o
Check hydraulic fluid filter and refill fluid	o
Check optical condition of machine	o
Test drive and function test	o

Maintenance and Care

Hako-System Maintenance II

The following maintenance works are to be performed by authorized HakoService-Centre.

Discription of task	Interval
	every 125 hours of operation
Clean battery terminals	o
Check service/parking brake and re-adjust if required	o
Check hydraulic fluid level	o
Check sweeping track and adjust if required (main- and sidebrush)	o
Check brush apron and adjust if required or change	o
Check sealings at filter system	o
Check V-belt for wearing and correct tension and re-adjust if required	o
Basic cleaning of the plate filter	o
Check optical condition of machine	o
Test drive and function test	o

Maintenance and Care

Hako-System Maintenance III

The following maintenance works are to be performed by authorized HakoService-Centre.

Discription of task	Interval
	every 250 hours of operation
Perform maintenance works according to Hako-System Maintenance II	o
Check tension of steering chain and adjust tension if required	o
Check tread of wheels	o
Change plate filter	o
Check lifted-up disposal function (2-hand-operation)	o
Check hydraulic hoses and replace if required	o
Check function of seat contact switch	o
Check cables and plugged connections for damages and tight fit	o
Check carbon brushes of the electric motor for free movement and wearing, cleanse of motor from coal dust and change carbon brushes if required (Hako Service Centre)	o

Maintenance and Care

Hako-System Maintenance S (Safety check)

The following maintenance works are to be performed by authorized HakoService-Centre at least once yearly.

Discription of task	Interval
	every 500 hours of operation
Perform maintenance works according to Hako-System Maintenance II and III	o
Change hydraulic fluid and filter	o
Check fixing screws (brake, steering wheel and lifted up disposal) and tighten if required (Safety check)	o
Check braking system (Safety check)	o
Check steering wheel (Safety check)	o
Test drive and function test of safety components	o

Maintenance and Care

5.4 Battery System

Battery System	Qty.	Order-No.
Battery System A:		
6 V/240 Ah, GiV block battery, maintenance-free	4	7401
Cable set for battery connection		6503
24 V/35A charger unit, variable IUlola and IUloU characteristic, 230V AC		4003
Battery System B:		
24 V/420 Ah tray battery, EPzS, with Aquamatik		7408
24 V/50A charger unit, variable IUlola and IUloU characteristic, 230V AC		4008



Before commencing any work on the electric system disconnect the battery plug. Do not use open flames when handling batteries and especially when checking the battery acid level. Provide for sufficient ventilation in rooms where batteries are charged. Spilled (straight) battery acid must not get into the sewage system before having been neutralised.



Comply with the regulations imposed by law and observe local provisions.



Open the hood before charging batteries; explosive gases may occur during the charging procedure.

Maintenance and Care

5.4.1 Low Discharge Signal Sender

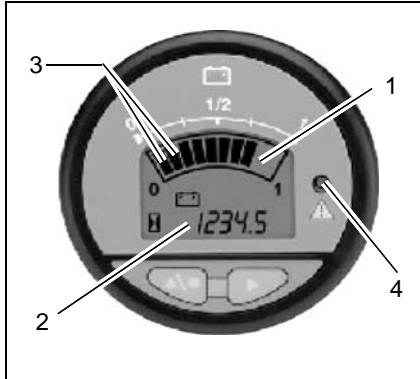

Fig.11



The factory setting is as follows:
tray battery 420 Ah EPzS.

5.4.2 Battery Charging Status Indicator

Upon turning ON by key switch, battery charging status is shown by display of green bars (Fig. 11/1). As the battery discharge during operation, the lighting green bars extinguish one after another showing thus always the current charge status of battery charge.

Flashing of the last two green bars (Fig. 11/3) indicates that operation will be stopped soon. In order to preclude low discharge of batteries, the sweeping units are switched off and riding speed reduced to 50% if battery is discharge. The red LED (Fig. 11/4) then flashes

5.4.3 Hourmeter

The operating hours of the machine appear in the display (Fig. 11/2); the hourmeter will count only during working or transport ride; only full hours are displayed.

5.4.4 Setting Other Battery Types



Have the low discharge signal sender set to other battery types by qualified personnel only and in approved qualified workstations only.

Maintenance and Care

5.4.5 Plug Connection Coding

The battery plugs of the machine, the battery and the stationary charger unit have to be coded according to the battery type and the nominal voltage with coloured pins.

The charger unit's plugs are/will be coded in the factory according to the characteristics curve and changing the characteristic curve (according to the battery type) always requires modification of the plug coding.

Plug case of charger unit:

- grey for wet batteries
- green for maintenance-free Gel batteries

Machine plug case:

- yellow for both battery types

Battery socket case:

- grey for wet batteries
- green for maintenance-free Gel batterie

Remove the coding pin by pressing the ends together by means of pliers.

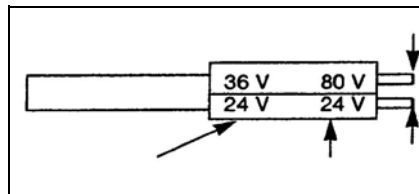

Press together for assembly.

Insert pin such that the nominal voltage inscription is visible through the case window. Socket and plug always with the same nominal voltage.

The following three requirements have to be met:

- 1 Voltage coding is the same for all plugs and socket
- 2 Coding pin colour in the machine = yellow
- 3 Coding pin colour



Before first operation of the machine, the batteries have to be adequately charged by an initial charging procedure.

Please observe the instruction of the charger unit's operating manual.

Hako rejects any claim for warranty on battery damages caused by unfulfilled initial charging.

Coding system in plug connectors for wet and dry batteries (example for 24 V)

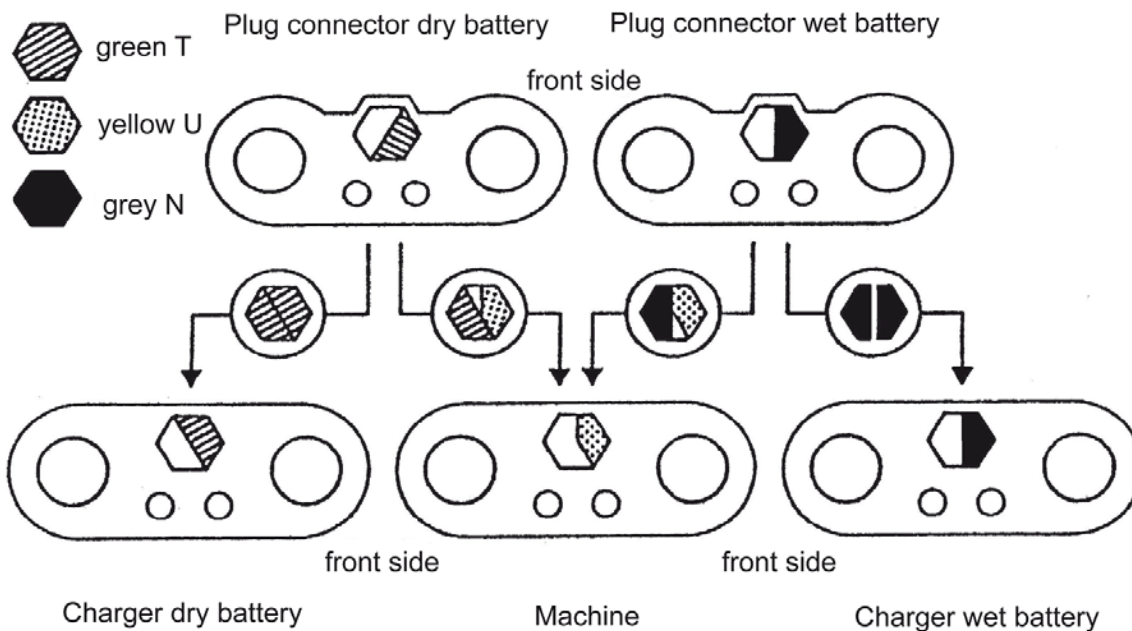

5.4.6 Batterie einsetzen

- Turn engine off and pull key.
- Secure machine by engaging the parking brake.
- Fold back seat hood.
- Insert batteries into the battery tray from the top. (Fig. 12/)



Fig.12

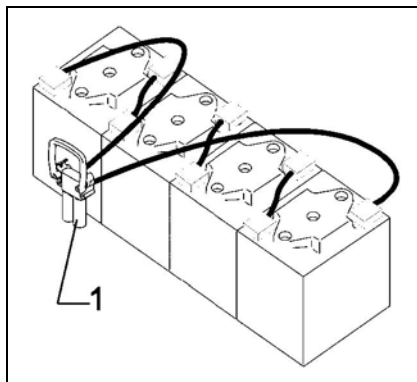

Fig.13

6 V/240 Ah, GiV maintenance-free

- Connect batteries and enclosed cable set according to (Fig. 13/) (check for tight seating) and grease poles.
 - Check set battery type at the low discharge signal sender or set if required.
 - Connect charging plug of the battery connection cable and cable of the charger unit and proceed to initial charging.
 - After charging of the batteries, connect charger plug and device plug for electrical connection (Fig. 13/1) .
- Now the Sweepmaster B1200 RH is operable.



If the battery type setting at the LDS should be incorrect, have the setting modified by qualified personnel in an approved workshop.

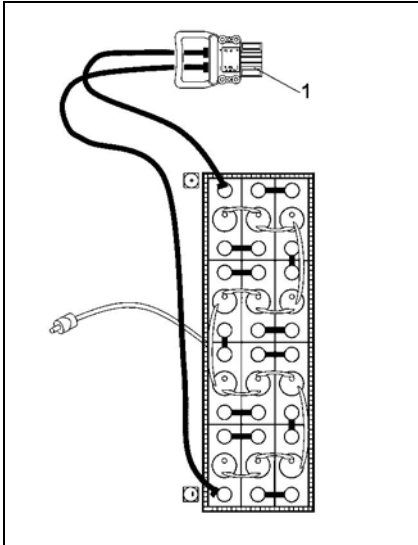

Fig.14

24 V/420 Ah tray battery, EPzS mit Aquamatik

- Turn machine off and pull key.
- Secure machine by actuating parking brake.
- Fold up seat hood.
- Insert battery.
- Connect charging plug of the battery connection cable and cable of the charger unit and proceed to initial charging.
- After charging of the batteries, connect charger plug and device plug for electrical connection.



If the battery type setting at the LDS should be incorrect, have the setting modified by qualified personnel in an approved workshop.



Use admitted lifting and transport devices such as e.g. lifting tackles according to VDI 3616. Make sure that lifting hooks do not damage cells, connectors or connecting cables.

Maintenance and Care

5.5 Sweeper Unit

5.5.1 Mount/Dismount Sweeper Roller

The sweeper roller is accessible from the left side of the machine and is to be dismantled as follows:

- Lower sweeper roller
- Pull key switch and protect by engaging parking brake.
- Open locks (Fig. 15/1) by enclosed square spanner (turn counter-clockwise).
- Remove cover (Fig. 15/2).
- Loosen star-shaped knob (Fig. 15/3) and remove.
- Remove sweeper roller seating (Fig. 15/4).
- Turn handle (Fig. 15/5) upwards and unlock.
- Remove plate with sealing strip (Fig. 15/6).
- Remove sweeper roller (Fig. 15/7) by pulling.

For mounting the sweeper roller proceed in inverse order.

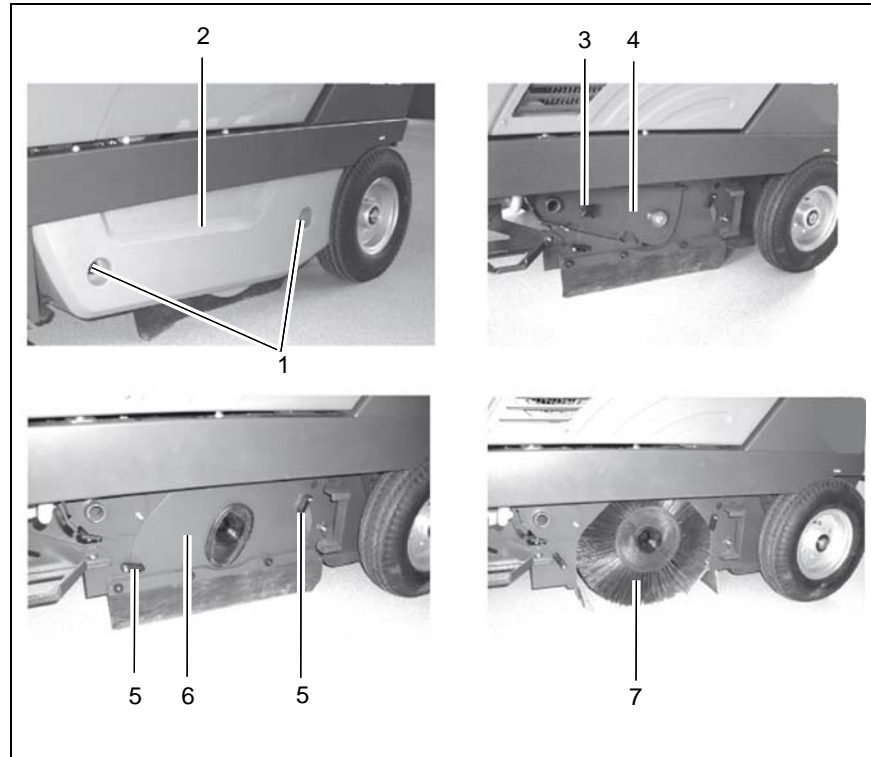

Fig.15

Maintenance and Care

5.5.2 Adjust Sweeping Track

An adjustment device allows adaption to different sweeping conditions. The sweeper roller has to be adjusted for normal use and with regard to a low degree of wearing as described in the following.

Check the sweeper adjustment on level ground as follows:



Before checking:
Mark level surface for checking sweeper adjustment by chalk (1000 x 300 mm).
Drive sweeping roller over underline floorspace.



Check inflation pressure of tyres (6bar).
Air tyres only.

- Secure machine by engaging parking brake.
- Lower sweeper roller and let it run dry.
- Lift sweeper roller and forward the Sweepmaster B1200 RH a bit. With the correct sweeper adjustment the parallel sweeping marks have to appear on the floor (sweeping track).

The sweeping track width is to be 70 mm with the Sweepmaster B1200 RH.

The sweeping track width can be adjusted at the star-shaped knob (Fig. 16/1) as follows:

- Stop machine and pull key switch.
- Engage parking brake.
- Open seat hood.
- Turn star-shaped knob (Fig. 16/1) to the left = wider sweeping track to the right = smaller sweeping track (Sweeper adjustment sticker (Fig. 16/2))

Fig.16

- Check sweeping track



With one full turn of the knob, the track widens or broadens by approx. 10mm.



When exceeding the sweeping track width the sweeper roller wearing increases as well as the load of the drive.

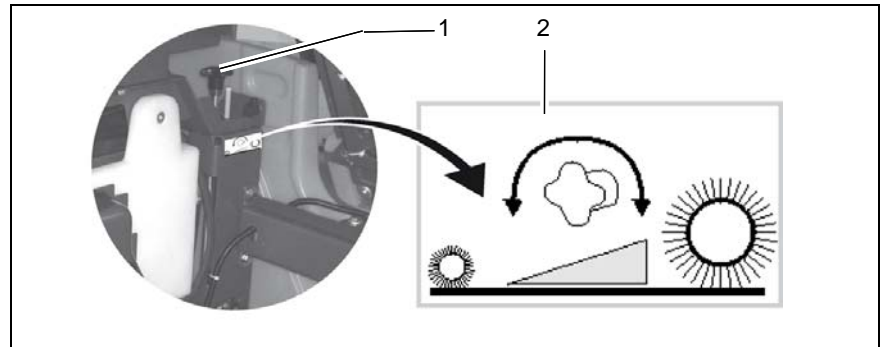

Maintenance and Care

5.5.3 Sealing Strips for Broom Compartment

In order to assure good function of the sweeper, a perfect condition of the sealing strips is required, especially in order to attain the prescribed low pressure in the broom compartment, a clean sweeping result and the less possible wear of the sealing strips. Check the sealing strips of the broom compartment for wearing and damages in regular intervals.

Replace defective sealing strips.

The ground clearance of the lateral and rear sealing strips is adjustable (oblong holes in the sealing strips).

Ground clearance:

sides approx. 1mm
rear approx. 4mm

Proceed to adjustment with an inflation pressure of the pneumatic tyres of 6 bar. Height of the front sealing strip (folding apron) cannot be adjusted. Being dragged, it has contact with the floor.

5.5.4 Replace Side Broom

The side broom is located at the front right of the machine (standard version). Use the lever (chapter 3.2.1, Fig. 10/2) to lift and lower the side broom.

The swinging area of the side broom is limited by stop screws.

The side broom is driven by hydraulic engine.

Fitting of a second side broom (left side) for specific appliances is possible.

Proceed as follows for dismounting of the side broom:

- Turn machine off and pull key switch.
- Secure machine by engaging parking brake.
- Side broom lifted.
- Loosen hexagonal nut (Fig. 17/1) below the side broom.
- Remove side broom.

Proceed in inverse order for mounting of the side broom.

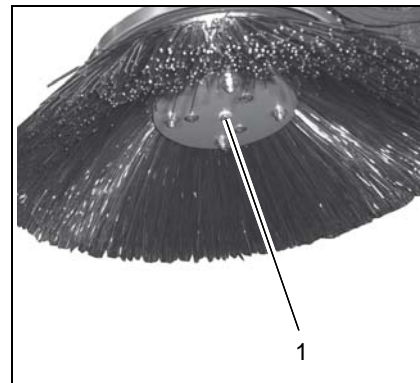

Fig.17



Check for correct mounting.

Maintenance and Care

5.5.5 Dismount Plate Filter

Proceed as follows for dismounting of the plate filter:

- Turn machine off and pull key switch.
- Secure machine by engaging parking brake.
- Open quick-release locks (Fig. 18/1) and remove cover (Fig. 18/2).
- Remove cover (Fig. 18/3) of the filter installation.
- Loosen wing screws, four peaces, (Fig. 18/4) and remove.
- Fold back frame (Fig. 18/5) and hook frame (Fig. 18/5) at indicated position by rubber fastening (Fig. 18/6).
- Remove plate filter (Fig. 18/7).

For mounting of plate filter proceed in inverse order.



Clean filter area.

Check plate filter of damaging. Watch for direction of the air on the plate filter.

Check for correct fit of the plate filter in the machine frame.

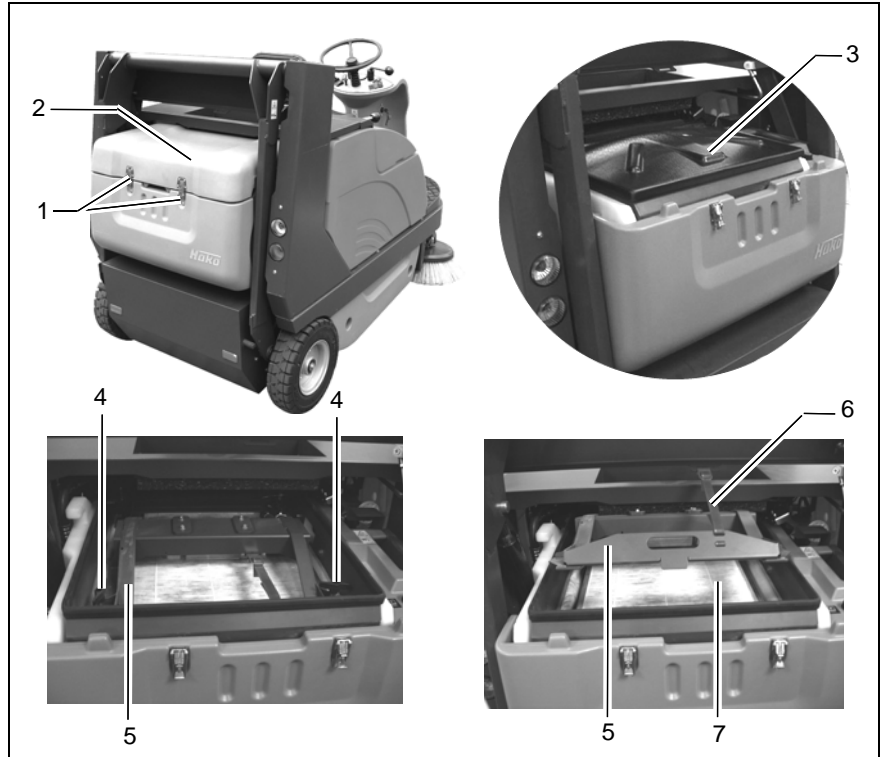

Fig.18

Maintenance and Care

5.5.6 Basic Cleaning of Plate Filter

Hold the plate filter (Fig. 19/1) in vertical position and drop it from a height of approx. 1m to the even floor as represented in (Fig. 19/).



The soiled side of the plate filter points to the bottom.

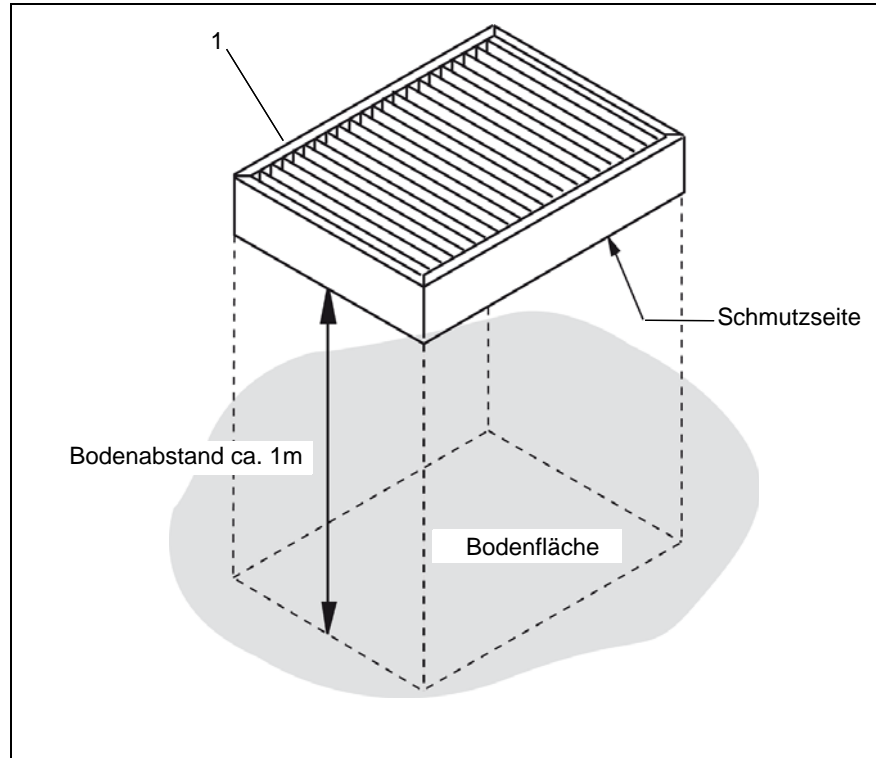

Fig.19

Maintenance and Care

5.6 Hydraulic System

The hydraulic units are oil- and maintenance-free. The hydraulic oil and filter concerned my maintenance work only. Premature failure can be prevented by regular inspection and periodical maintenance according to maintenance schedule.



We recommend having all other works at the hydraulic system done by a authorized Hako-service-workshop.

5.6.1 Check Hydraulic Fluid Level

- Turn machine off and pull key switch.
- Secure machine by engaging parking brake.
- Open quick-release locks (Fig. 20/1) and remove cover (Fig. 20/2)
- Clean the area of the dipstick (Fig. 20/3).
- Pull dipstick (Fig. 20/3).
- Wipe dipstick by means of cloth.
- Put in dipstick until stop.

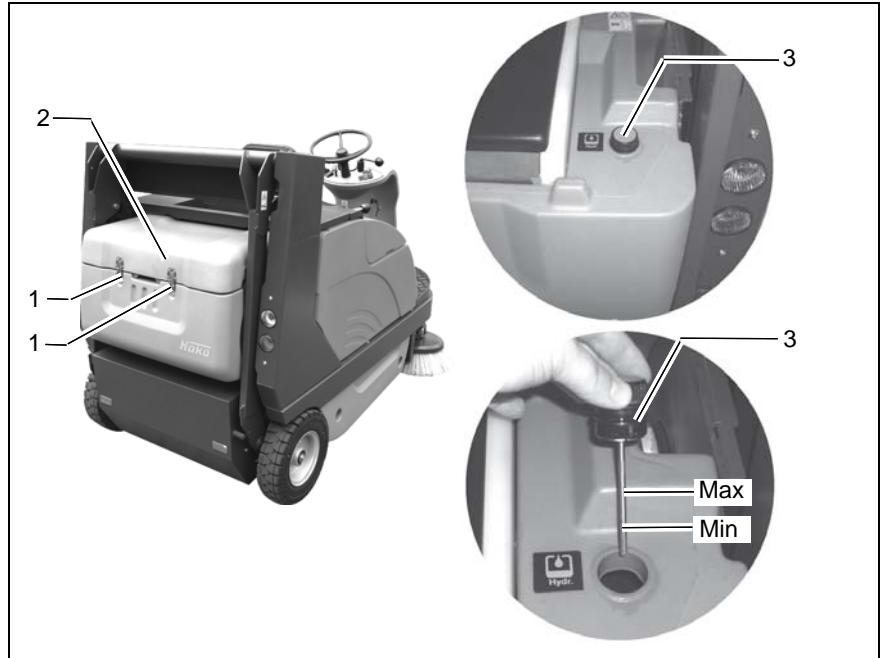

Fig.20

Maintenance and Care

- Pull dipstick (Fig. 20/3) and check the hydraulic fluid level, refill if required.

5.6.2 Refill Hydraulic Fluid

- Unscrew cap with dipstick (Fig. 20/2) and check hydraulic fluid level, siehe Abschnitt 5.6.1.
- Use appropriate oil-resistant recipient with mouth or funnel for refilling.
- Proceed to check of fluid level after refilling.
- The hydraulic fluid level must not fall below the minimum. It should read between the minimum and the maximum (Fig. 20/).

5.6.3 Change Hydraulic Filter

Change the hydraulic filter according to maintenance schedule.

For change hydraulic filter proceed as follows:

- Turn machine off and pull key switch.
- Secure machine by engaging parking brake.
- Open seat hood, loosen and remove the wing screws of the left side cover.
- Turn hydraulic filter (Fig. 21/1) counter-clockwise to loosen it and unscrew.
- Before screwing new filter, fill it with oil.
- Ride the machine a short distance.
- Refill sufficient hydraulic oil.
- Check fluid filling level.



Fig.21

Maintenance and Care

5.6.4 Change Hydraulic Fluid

Change the hydraulic fluid according to maintenance schedule.

For change hydraulic fluid proceed as follows:

- Move up the dirt hopper (Fig. 22/1).
- Turn machine off and pull key switch.
- Secure machine by engaging parking brake.
- Place recipient under the drain plug (Fig. 22/2), drain plug is located underneath the hydraulic case (Fig. 22/3), and remove drain plug (Fig. 22/2).
- Turn in the screw, observe of the O-ring.
- Refill hydraulic fluid, siehe Abschnitt 5.6.2

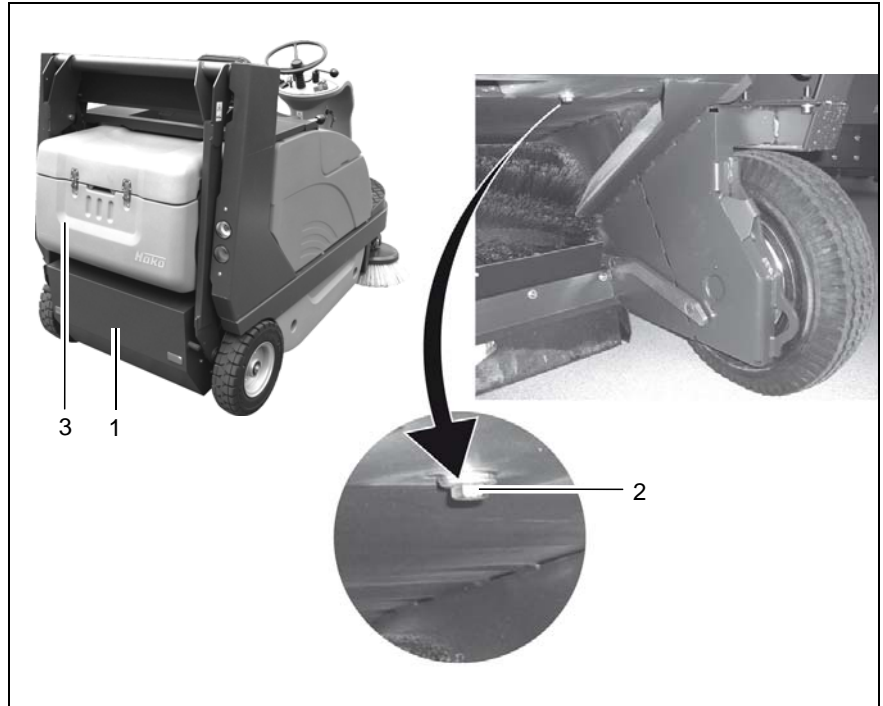

Fig.22

5.7 V-Belt Drive

- 1) Suction fan V-belt (75 Hz)
- 2) Tensioning device for suction fan
- 3) Hydraulic pump B-belt
- 4) Tensioning device for hydraulic pump (150 Hz)
- 5) V-belt for sweeper roller (75 Hz)
- 6) Tensioning lever for sweeper roller
- 7) V-belt for sweeper roller drive (90 Hz)
- 8) Tensioning device for sweeper roller drive

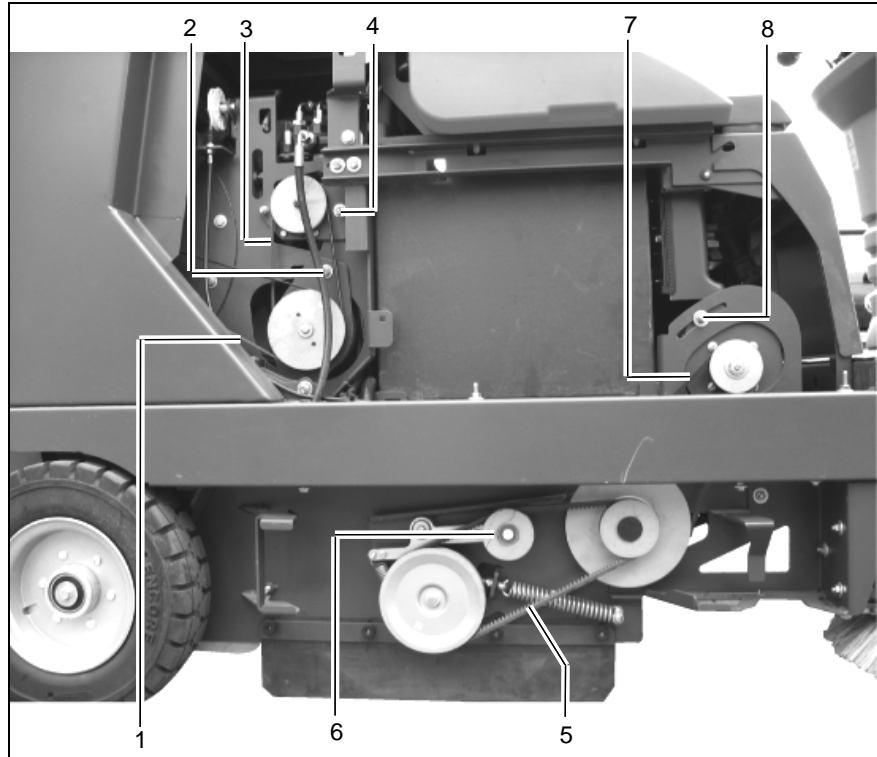

Fig.23

Maintenance and Care

5.8 Electric System

- F1 Drive(160A)
 - F2 Key switch(15A)
 - F3 Drive unit(10A)
 - F4 Battery charging status (5A)
 - F5 Horn/Side broom left (Option) (7.5A)
 - F6 Horn Side broom (Option) (2A)
 - F7 Filter control/Control unit Shaking motor (Option) (5A)
 - F8 Dust fan (30A), Option
 - F10 Floodlight/Rear light (10A) (Option)
 - F11 Floodlight/Warning light (11A) (Option)
 - F12 Parking- and rear light left (5A), Option
 - F13 (Parking- and rear light right (5A), Option
 - F14 Warning light (10A), Option
 - F15 Braking light (7.5A), Option
 - F16 Shaking motor (35A)
 - F18 Sweeper roller motor (63A)
 - F19 Fan/lifted-up disposal motor (63A)
- Battery plug (Fig. 24/A)

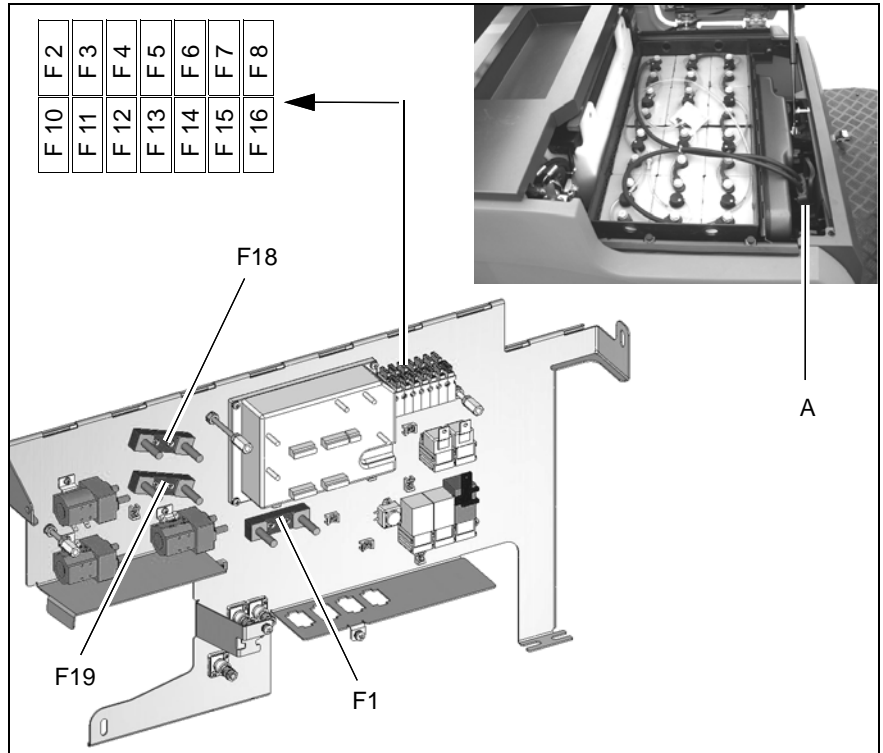

Fig.24

Maintenance and Care

- K1 Main protection Drive
- K2 Control circuit
- K3 Sweeper roller motor
- K4 Suction fan motor/Lifted-up disposal
- K7 On-delay Filter control
- K8 Shaking motor
- K9 Electric lighting (Option)
- K10 Flashing light relay (Option)

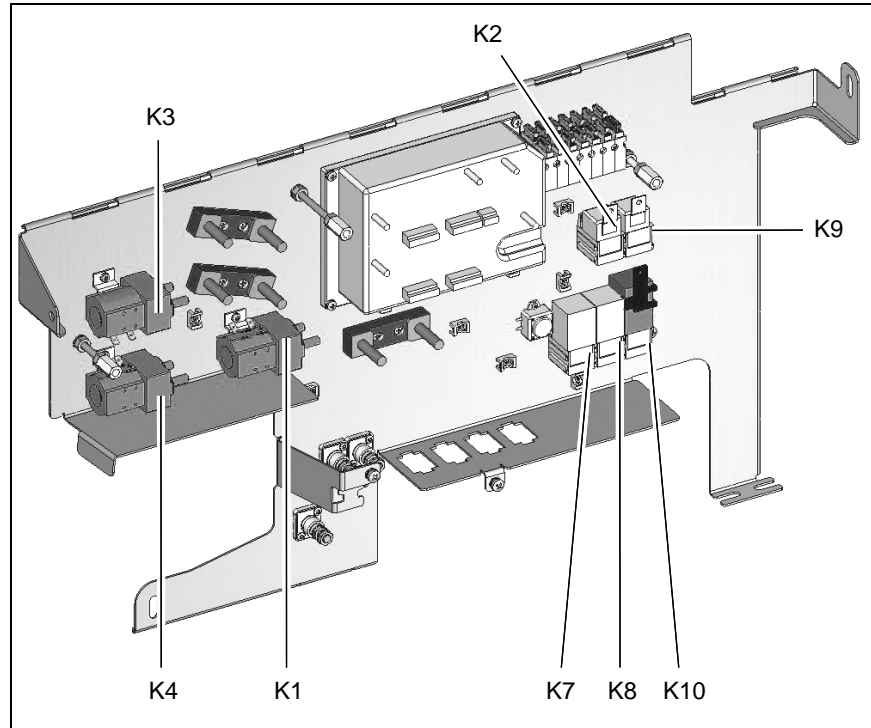

Fig.25

Maintenance and Care

5.9 Special Equipment and Spare Parts

Designation	Description	Order no..
Protective roof	For Hako Jonas 1200	6304
Side broom system left	With deflector plate, without brush	6315
Rotating beacon	For mounting on the protective roof	6307
Rotating beacon	For direct fitting	6308
High-Performance Filter	Superfine filter with special coating for dust-free sweeoin in prob-lematic areas	see spare part cat-aloque
Comfort seat	Seat features adjustable cushioning	7093
Solid rubber tyres	Set of punture-safe SE-Superelastic-tyres 4.00-4 (2 rear wheels on rim)	6334
Solid rubber tyres	Set of punture-safe SE-Superelastic-tyres 4.00-4, leaving no traces (2 rear wheels on rim)	6335
Lighting system	Front light (according to german StVZO)	6341
Lighting system	according to german StVZO, 24V	6310
Technical Control Board - Certificate	according to german TÜV	9022
Sweeper roller	Polyester bristling	6318
Sweeper roller	Polyamid bristling	6312
Side broom	Polyester bristling	6415

Maintenance and Care

Designation	Description	Order no..
Side broom	PES bristling (PA 2)	6423
Side broom	PES bristling (PA 1.5)	6414

EC-Declaration of Conformity (according to Directive 2006/42/EC)

Hako GmbH
Hamburger Straße 209-239
D-23843 Bad Oldesloe

declare under our sole responsibility,
that the product

Sweepmaster B1200 RH
Typ: 6300.30

to which this declaration relates, corresponds to the relevant basic safety and health requirement of the Directive 2006/42/EC, and to the requirements of the other relevant Directives: 2004/108/EC.

For the relevant implementation of the safety and health requirements mentioned in the Directives, the following standard (s) and / or technical specification (s) has (have) been respected:

DIN EN 60335-2-72
DIN EN 55012
DIN EN 61000-6-2

Bad Oldesloe, 22.04.2014



Dr. Rainer Bavendiek
Director R&D

Name of the person authorised for Hako to compile the technical file:

Ludger Lüttel

Hako

Clean ahead

Spitzentechnik für eine saubere und schönere Umwelt

Advanced Technology for a Cleaner, Better Environment



Hako GmbH • Hamburger Str. 209-239 • D-23843 Bad Oldesloe
☎ +49 4531 806-0 • Fax +49 4531 806-338

88-10-2772 - 3100-11